

ULTRAFLO 2000 FLOW & HEATMETER

Operating Manual

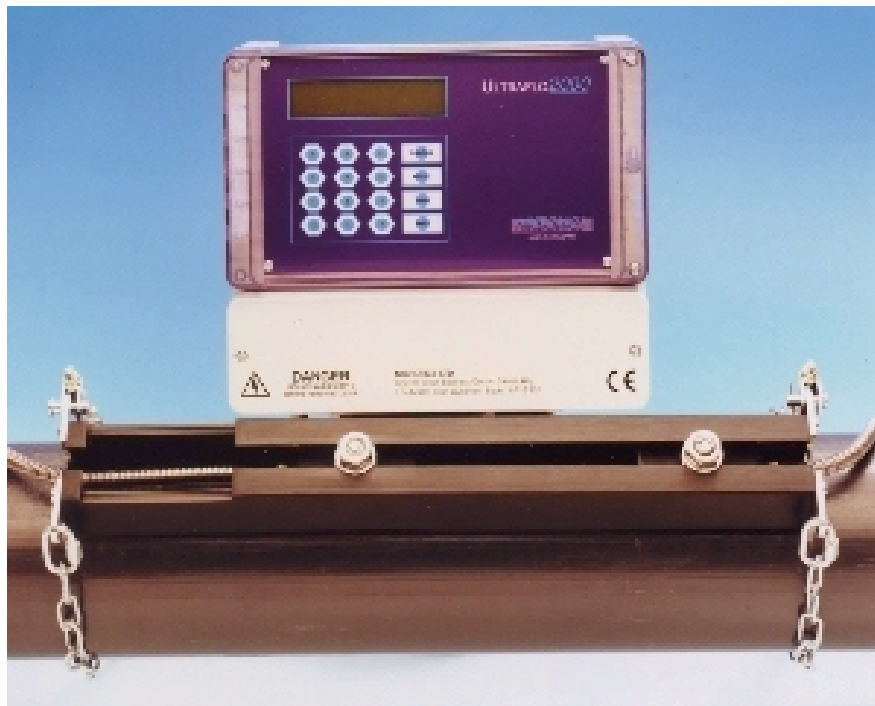

Micronics Limited, Unit B3 Knaves Beech Business Centre, Davies Way, High Wycombe, Bucks HP10 9QR UK.
Tel: 01628 810456 Fax: 01628 531540 e-mail sales@micronicsltd.co.uk www.micronicsltd.co.uk

CONTENTS

SYSTEM IDENTIFICATION	3	ERROR MESSAGES	
INTRODUCTION	4	E1:High Flow	16
HARDWARE		E2:No Flow Sig	16
Electronics Housing	4	E3:Hot Fault	16
Transducers	4	E4:Cold Fault	16
Transducer Connections	4	WARNING MESSAGES	
Transducer Hardware	5	W1:Check Data	16
Transducer Mounting	5	W2:Timing Poor	16
Transducer Cables	6	W3:Signals Poor	16
Keypad	6	W4:Ma (1) OVER	16
		W5:Ma (2) OVER	16
		W6:Pulse At Max	17
MAIN MENU		APPLICATION INFORMATION	
Power up	7	Application Notes	17
Quick Start	8	Select a Metering Position	17
View/Edit Site Data	10	Mounting The Transducers	18
Set-up Sensors	11	Liquid Conditions	19
Calibrate 4-20mA	12	Propagation Velocity	19
Read Flow	12	Maximum Flow	19
		Application Temperature	19
FUNCTIONS		Flow Range	19
Display	13	SPECIFICATION	20
Set-up 4-20mA	13	HEATMETER INSTRUCTIONS	21
Pulses/Set Point	14	CE MARKING Guidance Notes	22
CutOff M/S	15	WARRANTY	22
Set Zero Flow	15		
Reset Total Flow	15		
Reset Total Energy	15		
Damping	15		
Cal Factor	16		
Diagnostics	16		
Save And Exit	16		

WARNING - users should ensure or note that:

- a) The Ultraflo 2000 is not certified for use in hazardous areas.
- b) The local site safety regulations are complied with.
- c) Work is carried out in accordance with The Health & Safety at Work Act 1974.

FIGURE 1 - SYSTEM IDENTIFICATION

FLOW SENSORS ASSEMBLY

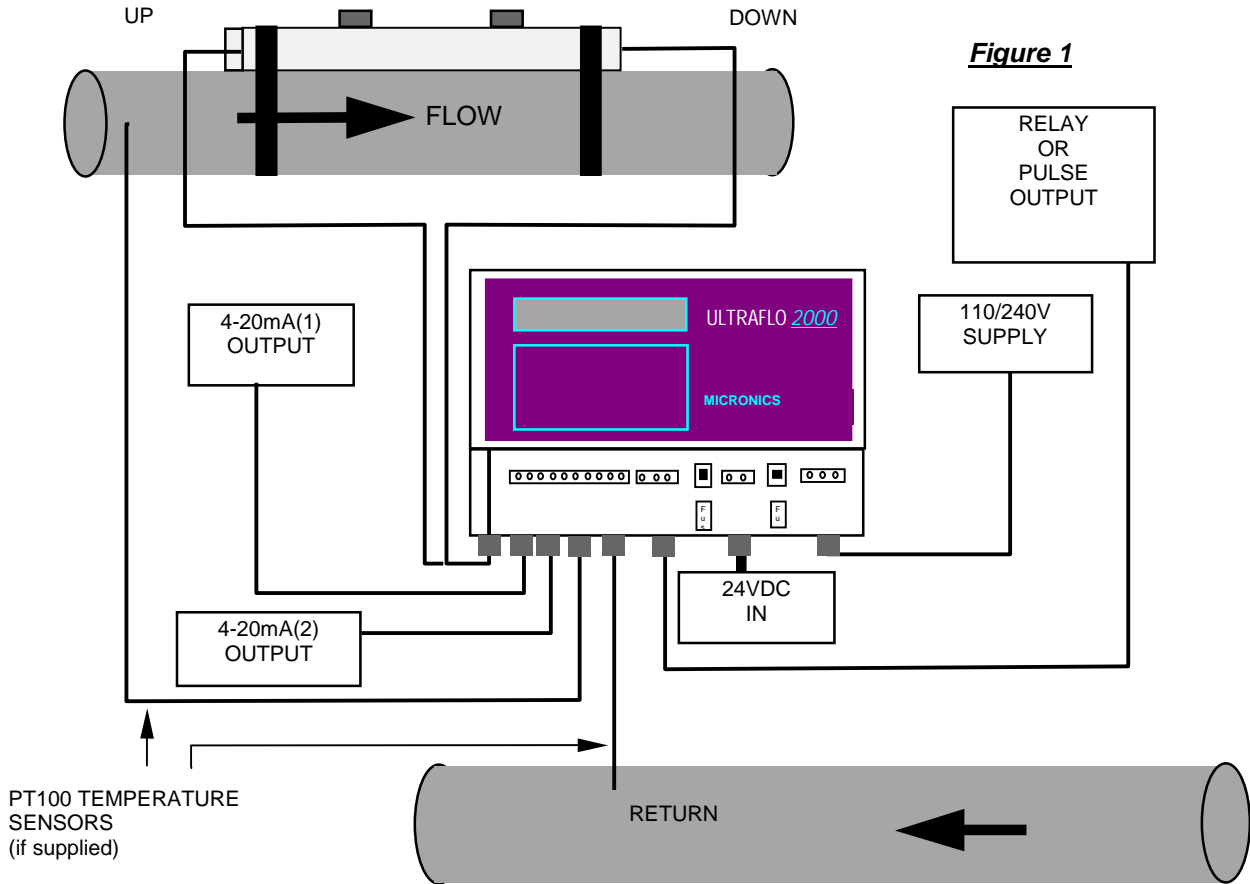

Figure 1

The following information is required by Micronics when placing an order.

EXAMPLE

POWER VOLTAGE.....	24v DC
PIPE OD.....	60
PIPE MATERIAL	STEEL
APPLICATION TEMP.....	60°C
LIQUID	WATER
TRANSDUCER CABLE LENGTH.....	50 METRES
MAX FLOW IN UNITS.....	150L/MIN
MAX ENERGY RATE	
(HEATMETER ONLY)	1000KW
TEMPERATURE DIFFERENTIAL	
(HEATMETER ONLY).....	25°C
TEMPERATURE PROBE CABLE	
LENGTH (HEATMETER ONLY).....	50 METRES

Example Order Code 24-60-S-60-W-50-150L/min

INTRODUCTION

The Ultraflo 2000 is a "Clamp-on" liquid flow meter that uses the Transit Time method of measurement to read flow. Using two PT100 temperature probes to measure temperature it can also be used as a Heat/Energy meter.

The Ultraflo is able to measure the flow of liquid in any pipe from 13mm to 5000mm, providing the pipe is flooded and the correct transducers are used. Units are supplied according to application data provided by the customer.

The instrument displays volumetric flow rate in m³/hr, m³/min, m³/sec, g/min, USg/hr, l/min, l/sec and linear velocity in metres and feet per second. The total volume of flow will be displayed, up to a maximum 12-digit number. When supplied as a Heatmeter, kW, kCal/hr, MJ/hr, MJ/min and MJ/sec can be displayed, as well as the temperature differential.

The flowmeter is supplied with electronics, sensors and all mounting hardware. The Heatmeter version will also be supplied with PT100 temperature probes.

HARDWARE

Electronics Housing

An ABS housing with an opaque door contains the master PCB. The housing is designed for wall mounting using the brackets provided (see Figure 2 for mounting pattern). Drilling further fixing holes in the Housing remove the IP67 protection rating and CE approval.

Mounting the housing into position does not require the removal of the electronics or the front display panel.

Figure 2

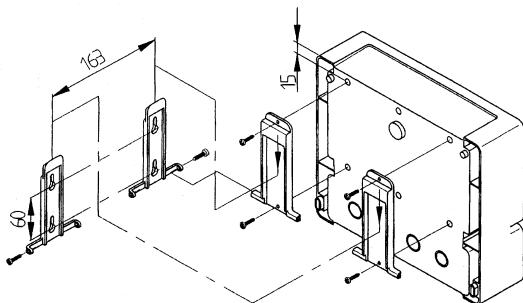

DO NOT PROVIDE POWER to the instrument until the service compartment cover has been replaced.

The electronics are factory set for a particular supply voltage. Should it be necessary to change the settings for the power supply see page 7, Power up.

Having completed the procedure for mounting the electronics, connecting all cables and checking

the power supply, the power can now be applied. The Ultraflo 2000 is now ready for programming. A full programming procedure is described on page 7.

Before programming the instrument, it is necessary to attach the transducers to the pipe wall such that they can be finally locked in the correct position based on exact data provided by the instrument.

TRANSDUCERS

Each instrument uses two identical transducers, which transmit and receive the ultrasonic waves. They are clamped to the pipe surface using the mounting hardware supplied, as described on pages 5, 6.

The standard transducers are made from a Peek material with an aluminium plate supporting the stud, used to lock the sensor in position. A flying armoured lead is attached between the sensor block and the tuning circuit.

Figure 3 – 1MHz Sensors with TNC Coaxial Connector

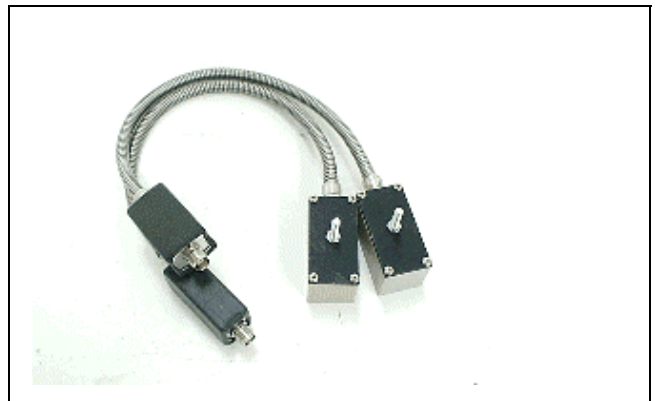

Transducers are supplied according to the pipe size and flow velocity, and are available to meet an operating temperature range from -20°C up to +200°C.

Transducer Connections

Transducers are connected to the electronics from the tuning circuit by TNC connectors. All other output and input connections are made through metal glands to the clearly marked terminals.

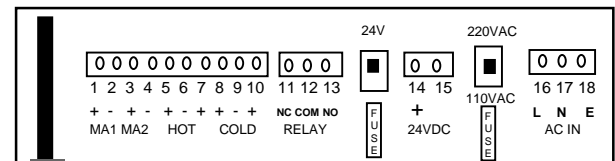

Only one current output can be used with the flow meter, but both can be used when the Heatmeter option is supplied. Connections 5-10 can only be used when the PT100 temperature probes are supplied with the Heatmeter.

Transducer Hardware

Transducer alignment guide rails, chains and couplant are supplied with all units in order to ensure that the transducers are accurately aligned with respect to the pipe axis.

A single guide rail assembly is supplied for mounting the transducers in Reflex mode and two guide rails are provided for mounting in Diagonal mode.

Figure 4 – 1MHz Reflex Mounting Assembly

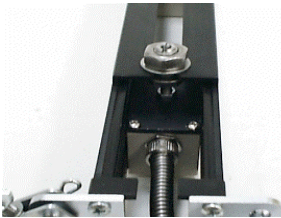
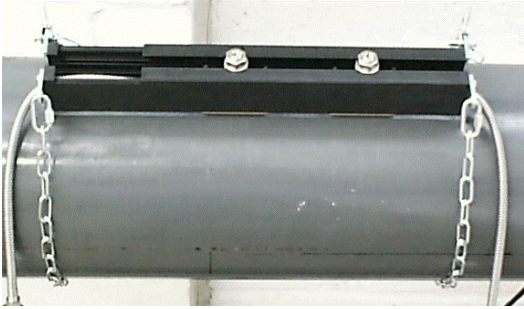
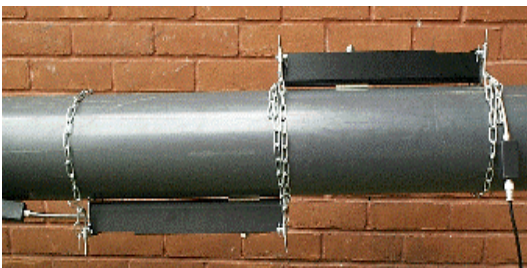

Figure 5 - Diagonal Beam Mounting Hardware



Transducer Mounting

The two different methods of mounting the transducers are shown on pages 5 & 6. When ordering the Ultraflo 2000 specific application information should have been given. This information determines the correct hardware to be supplied with each instrument.

Reflex Mode

Reflex mode is a default setting on all applications up to 215mm. Above this the instrument will default to Diagonal mode. It is possible to change these default settings if required (see page 11 Set up sensors).

Before attempting to attach the transducers it is imperative to ensure that the correct position has been chosen to site the transducers and that the pipe surface conditions are suitable. Go to page 17 and carefully follow all instructions for the

selecting and preparing the transducer mounting site.

At this point program the instrument to determine the separation distance. When you have this information from the instrument follow the set up procedure below.

Procedure

- a) Insert the transducers into the guide rail so the tails come out of either end.
- b) By turning the locking nut centre clockwise, withdraw the transducers up into the guide rail.
- c) Apply a bead of coupling grease to each transducer. See page 19, figure 15.
- d) Attach both lengths of chain to the quick links provided and offer the guide rail up to the pipe wall at 45°.
- e) Wrap the chain around the pipe and connect to the 'J' bolt. Complete the same for both ends of the guide rail then tighten the locking nuts on the 'J' bolt. This will secure the complete assembly to the pipe.
- f) By turning the centre of the locking assembly anti-clockwise lower one block onto the pipe. Now adjust the second block to required separation distance and repeat the procedure. The separation distance is measured from the front edge of each block and not the centre of the locking nut.
- g) If the instrument now reads a negative flow swapping the TNC connectors on the instrument can change this.
- h) Now lock the transducers in position by tightening the nut on locking assembly. "DO NOT USE EXCESS PRESSURE".

Note: When moving the transducers into position ensure that they are withdrawn into the guide rail as far as possible. This ensures that the couplant will not be removed from the transducer face before it is screwed down into position.

Figure 6

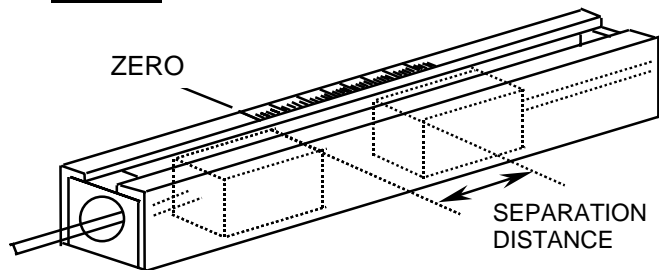

All transducers are mounted in Reflex or Diagonal mode as described on page 5 and 6. The guide rail assemblies are held in position using chains.

Diagonal Beam Mode

Diagonal beam mounting means the two transducer blocks are mounted on opposite sides of the pipe as shown in figure 7. This is the default setting for all applications above 215mm.

If you encounter a difficult application or the maximum flow velocity is outside of the default operating range, when working in the Reflex mode, it is possible to reprogram the instrument to operate in Diagonal mode (see page 11, Set up Sensors)

Diagonal Set up Procedure

- a) Using whatever means available mark a reference line around the circumference of the pipe (reference line D). As shown in figure 7.
- b) Locate and mark two positions exactly 180° apart around this reference line.
- c) On both of these positions draw a reference line (E) perpendicular to line (D), parallel to the pipe axis and approximately 1 metre long. See figure 7.
- d) Take each of the guide rails and load the transducers as described previously on page 5. Only one transducer goes in each guide rail.
- d) Attach the one guide rail to the pipe using the chain provided, such that it is parallel to the reference line (E) and position so that the transducer face can be aligned with reference line (D).
- e) Program the flow meter and obtain the separation distance.
- f) From the intersection of the circumference reference line (D) and the second reference line (E) measure and mark the separation distance XXX. Now mount the second guide rail such that the transducer face can be positioned on this intersection ensuring that the guide rail is parallel to the reference line (E). See figure 7.
- g) Screw down both of the transducers and lock in position as previously described.
- h) RG223 Coaxial Cable (50ohm), Different lengths up to 200 metres available on request.

Figure 7

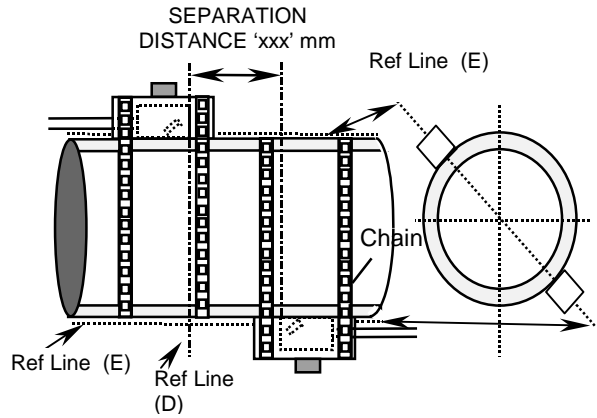

HINT: DRAWING A TRUE CIRCUMFERENCE AROUND A PIPE

An easy way to draw a perpendicular circumference around a large pipe is to wrap a length of material such as chart paper around the pipe, aligning the edges of the paper precisely at the overlap. With the edge of the chart paper being parallel, then either edge describes a circumference around the pipe that is perpendicular to the pipe axis.

BISECTING THE CIRCUMFERENCE

Mark the chart paper exactly where it overlaps. Then after removing the paper from the pipe, fold the measured length in half keeping the edges parallel. The fold line now marks a distance exactly half way around the pipe. Put the paper back on the pipe and use the fold line to mark the opposite side of the pipe.

Transducer Cables

The transducers are connected to the electronics via 50ohm coaxial cables and TNC connectors. The total length of the cable be up to a maximum of 200 mteres.

Keypad

All data is entered for set up and calibration via the front panel keypad. Figure 9 shows the keypad layout.

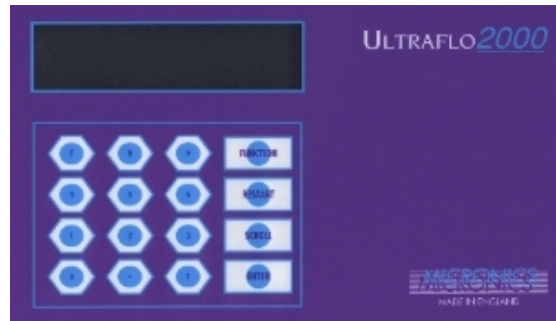

Keys

- To give a NO answer and scroll through listed options, press SCROLL.
- To select options, store data and move on to the next option, press ENTER.

- If data has been incorrectly entered, press Y until the display is clear, then re-enter the data correctly.

Restart Key

The RESTART key can be pressed at any point in the program and will take the instrument back to the opening display. Press SCROLL to enter the password 2000 and reprogram the instrument. If the instrument has already been measuring flow and the SCROLL key is not pressed, it automatically returns to flow mode.

Scroll Key

When the SCROLL key is pressed in flow mode the display will read the following.

Signal 80%
0.00 mA

This displays the signal level of the instrument and the current output status of the 4-20mA. Both will be displayed if a Heatmeter is supplied.

Press ENTER again and the following will be displayed.

ERRORS PENDING
No errors

This will display all Error and Warning messages (see page 16). To program the Ultraflo 2000, accurate application data must be keyed in via the keypad. Data and instructions are requested via the display and all questions must be answered before the program will step through to the point of measuring flow.

Once the unit has been programmed the data can be reviewed and changed if necessary.

The instrument displays information in the following 3 ways.

Flow in selected units.

l/min	0.00
l	0.00

Energy in selected units.

kW	0.00
kWh	0.00

Temperature differential.

H 50°C	C 10°C
Diff	40°C

The flow information can be factored to suit the users requirements by selecting CAL FACTOR from the FUNCTIONS menu. The Totalised Flow data can also be reset to zero.

PROGRAMMING/MAIN MENU

Power Up

DO NOT PROVIDE POWER TO THE INSTRUMENT UNTIL THE SERVICE COMPARTMENT COVER HAS BEEN REPLACED.

The power supply is factory set. To change from 110/220VAC to 24VDC the left hand switch needs to be in the down position. The right hand switch is only used when changing from 110VAC to 220VAC.

When power is applied to the Ultraflo 2000 it will react in 2 distinctly different ways depending upon whether any application data has been programmed into the EEROM.

All new meters received from the factory will have had the EEROM memory wiped clean.

Apply power. Initial display will show

Micronics Ltd
ULTRAFLO 2000

Within 5 seconds the display will change to

DIMENSION
Millimetres

Application data can now be keyed in.

If the instrument has been used then application data will be stored in the EEROM and the following will be displayed. If SCROLL is not pressed within 5 seconds after the initial display, the instrument will go directly to flow mode.

Apply power. Initial display will show

Micronics Ltd
ULTRAFLO 2000

PRESS SCROLL within 5 seconds of initial start up Display will then show

ENTER PASSWORD

Key in password 2000 (only required if the unit has been previously used)

ENTER PASSWORD
* * * *

Display will show:

MAIN MENU
Quick Start

MAIN MENU

To get into the **MAIN MENU** press RESTART, SCROLL, then enter the password 2000. The **MAIN MENU** has 5 options that are selectable by using the scroll key.

Press ENTER to select.

MAIN MENU
Quick Start
View/Edit Site
Setup sensors
Calibrate 4-20mA
Read flow

MAIN MENU - Quick Start

The **Quick Start** option enables the user to quickly read flow.

The display will show the following.

MAIN MENU
Quick Start

Press ENTER to select this option and enter application data. The user now has the option of selecting millimetres or inches.

Press SCROLL to display units and ENTER to select.

DIMENSION
Millimetres
Inches

The display will show the following. Enter the outside diameter and press ENTER.

PIPE OD
mm/inches

Enter the wall thickness in the selected units and press ENTER.

WALL **THICKNESS**
mm/inches

The display will show the following.

LINING THICKNESS
mm/inches

If the pipe has a LINING enter the thickness now and press ENTER. If there is no LINING press ENTER to continue.

WALL
M/Steel

The display will show the following.

There are 11 wall material options that are selectable by using the scroll key.

Select the material required and press ENTER when displayed.

WALL
M/Steel
S/Steel 316
S/Steel 303
Plastic
Cast Iron
Ductile Iron
Copper
Brass
Concrete
Glass
Other m/s

If **Other m/s** is selected the user needs to enter the speed of sound in metres per second of the particular pipe material being used. Enter a figure and press ENTER. Contact Micronics if the sound speed is not known.

If a Lining material thickness has been selected the following is displayed.

LINING
Steel

There are 6 Lining material options that are selectable by using the scroll key. These are only displayed if a Lining was selected previously.

Select the material required then press ENTER to select.

LINING
Steel
Rubber
Glass
Epoxy
Concrete
Other m/s

If **Other m/s** is selected the user needs to know the speed of sound in metres per second of the particular lining material being used. Enter a figure

and press ENTER. Contact Micronics if the sound speed is not known.

The display will show the following.

FLUID
Water

Press Scroll. There are 6 fluid options that are selectable by using the scroll key.

Select the fluid required then press enter to select.

FLUID
Water
Glycol 50%
Lub oil
Diesel oil
Freon
Other m/s

If **Other m/s** is selected the user needs to know the speed of sound in metres per second of the particular fluid being measured. Enter a figure and press ENTER. Contact Micronics if the sound speed is not known.

The display will show the following.

FLUID TEMP
°C

To enter a minus temperature press **Y** on the keypad. When the temperature has been entered press ENTER. The Ultraflo has a temperature range between -20°C and +200°C.

If the temperature entered is out of range the following will be displayed.

Temp out of rang
Press any key

When the correct temperature is entered the following will be displayed.

Approx. max flow
**** l/m

NOTE: If you have purchased a Heatmeter the following will be displayed unless water has been selected.

RELATIVE SHC
XXX

Enter the specific heat capacity of the liquid being measured (**Heatmeter only. See Heatmeter Instructions on page 21**) and press Enter.

If you have entered a SHC the following will now be displayed.

RELATIVE DENSITY
XXX

Enter the relative density of the liquid being measured (**Heatmeter only. See the Heatmeter instructions on page 21**) and press Enter.

The following will now be displayed.

Approx. max flow
**** l/m

The data that is entered and the application information that has been given to Micronics when purchasing the equipment determine the approximate maximum flow. The instrument will always default to litres per minute.

The instrument now displays the maximum flow rate that it is capable of with the sensors provided and the application data that has been entered by the user.

Pressing SCROLL at this point will allow the user to change the units to be displayed in the flow mode.

Press ENTER when the units have been selected. The Heatmeter option will also display kW, Kcal/h, MJ/h, MJ/m, kJ/m, kJ/s and Temp °C.

Approx max flow

**** l/s
**** l/m
**** Ml/d
**** g/m
**** kg/h
**** Usg/m
**** Uskg/h
**** m3/h
**** m3/m
**** m3/s
**** m/s
**** ft/s

The following will now be displayed.

Attach sensors
REFLEX Sep *** mm/inches

Pressing ENTER at this point will take the instrument into reading flow.

l/m	0.00
l	000.0

MAIN MENU - View/Edit Site

From the **MAIN MENU** select **View/Edit site** data by pressing ENTER. This enables the user to view and edit the application data that has been entered into the unit previously.

The display will show the following. Press ENTER to select.

l/m	0.00
l	000.0

The display will show the following. Press ENTER to select.

MAIN MENU
View/Edit Site

The display will show the following.

VIEW/EDIT SITE	
Dimension	MM/INCHES

To change the dimensions press ENTER. Select the units by pressing SCROLL. Press ENTER to select. This will convert all previous data entered, into the units selected.

The display will now show the following.

VIEW/EDIT SITE	
Pipe OD	55.0

To change the outside diameter of the pipe press ENTER. Enter the new outside diameter in the units selected previously and press ENTER.

The display will now show the following.

VIEW/EDIT	SITE
Wall thickness	3.0

To change the pipe wall thickness press ENTER. Enter the new wall thickness in the units selected and press ENTER.

The display will now show the following.

VIEW/EDIT SITE	
Lining thick	0.0

To change or enter a pipe lining thickness press ENTER. Enter the new lining thickness in the units selected previously and press ENTER.

The display will now show the following

VIEW/EDIT SITE	
Wall	M/Steel

To change the wall material of the pipe press ENTER. Scrolls through the options, press ENTER when a new material has been selected.

The display will now show the following.

VIEW/EDIT SITE	
Lining	-- --

It will only be possible to change the pipe lining material if a lining thickness has been entered previously. To change the lining material press ENTER. Use the SCROLL key to select from the options available and press ENTER.

The display will now show the following.

VIEW/EDIT SITE	
Fluid	WATER

To change the fluid type press ENTER. Use the scroll key to select from the options available and press ENTER.

The display will now show the following.

VIEW/EDIT SITE	
Fluid °C	20.0

To change the fluid temperature press ENTER. Press ENTER again when a new temperature has been entered.

The display will now show the following.

VIEW/EDIT SITE
Read flow

Pressing SCROLL at this point will ask the user if they wish to exit the **VIEW/EDIT SITE** loop. Pressing ENTER will take the instrument back to the **MAIN MENU** option, **Setup sensors**.

Pressing ENTER will display the following.

Approx max flow
**** l/m

To change the flow units press SCROLL and use the scroll key to select from the options available and press ENTER.

Pressing ENTER will display the following.

Attach sensors	
REFLEX Sep	10.2

Pressing ENTER at this point will take the instrument into reading flow.

l/m	0.00
------------	-------------

I	000.0
---	-------

MAIN MENU - Setup sensors
Press ENTER to select this option.

MAIN MENU Setup sensors

This gives the user the opportunity to change the mode of operation from Reflex to Diagonal (see figure 5, page 5).

When application information is programmed into the instrument it automatically selects the mode of operation from that data. It is possible however to use the same sensors in different modes.

The **Setup sensors** option is available for two main reasons. Firstly, if from the data that has been entered the instruction comes back that the sensors should be mounted in Diagonal mode, it may be that this is not possible in the case of a partially buried pipe. Under these circumstances, provided that the velocity is low enough it may be possible to use the transducers provided in Reflex mode (see figure 4, page 5).

The second reason for this option is that in the case of applications where the signal strength is not strong enough to get through a corroded pipe in Reflex mode, the instrument may be used in Diagonal mode. This has the effect of increasing the signal strength and maximum flow velocity.

The display will read the following.

SETUP SENSORS Mode	REFLEX
------------------------------	--------

To change the mode of operation press ENTER. There are 4 options under the heading of **SETUP SENSORS** and these are selectable by pressing scroll.

The display will show the following.

SETUP SENSORS Mode	REFLEX
Sensor params Read flow Exit and default	

Select mode of operation by pressing SCROLL then press ENTER.

SETUP SENSORS Mode	REFLEX
------------------------------	--------

The display will show the following.

MODE Reflex

Pressing SCROLL will allow you to choose between Reflex and Diagonal operation. Press ENTER when new mode is selected.

The display will show the following.

SETUP SENSORS Sensor params

The user cannot change this option. It is only used by Micronics engineers to set sensor parameters for a particular application and to make sure the correct transducers are supplied with the instrument. If this option is selected in error the instrument will ask for a password that is only known by Micronics engineers. Pressing SCROLL will move the instrument onto the next option.

The display will show the following.

SETUP SENSORS Read flow

If the sensor mode has been changed from the default settings (i.e. Reflex to Diagonal or Diagonal to Reflex) then this option will have to be selected to make sure that the new mode of operation is used to read flow. If this is not selected the default settings will be used.

The display will show the following.

SETUP SENSORS Exit and default
--

Press ENTER at this point to Exit and return to the MAIN MENU. This will re-set all the default sensor settings in the instrument that may have been changed by the user.

Pressing ENTER to continue will display the following.

Approx max flow
 * * * * l/m

Pressing ENTER again displays the following.

Attach sensors
 REFLEX Sep * * * mm/inches

The instrument now displays the mode of operation and separation distance. Attach the transducers as described on pages 5 and 6.

Pressing ENTER will take the instrument into reading flow.

l/m	0.00
l	000.0

MAIN MENU - Calibrate 4-20mA

(Note: A meter is required to measure the output current)

The display will read the following. Press ENTER to select.

MAIN MENU
 Calibrate 4-20mA

The 4-20mA output is calibrated before it leaves the factory and should not need adjusting, although this option allows the user to adjust it if necessary to match a specific requirement. The DAC value is a number between 0 and 40,000, which is a number internal to the Ultraflo.

The first stage is to adjust the output current to 4mA. Use the scroll key, decimal point key or keys 5 and 6. The scroll and decimal point key move the DAC value in large steps of 25. Keys 5 and 6 move the value one digit at a time.

The DAC value should be approximately 8000 for 4mA and 40,000 for 20mA. By watching the actual current value displayed on the meter, it is possible to set this exactly.

The display will show the following.

CAL 4mA	
DAC value:	8000

Use the scroll and decimal point key to set and keys 5 and 6 to trim. Press ENTER when complete.

The display will then show the following.

CAL 20mA	
DAC value:	40000

Use the scroll and decimal point key to set 20mA and keys 5 and 6 to trim. Press ENTER when complete.

The following will be displayed. Press SCROLL.

MAIN MENU
 Calibrate 4-20mA

The following will be displayed.

MAIN MENU
 Read flow

MAIN MENU - Read flow

Pressing SCROLL will take the instrument back to **MAIN MENU-Quick start.**

Pressing ENTER displays the following.

Approx max flow
 * * * * l/m

It is possible to change the flow units by pressing SCROLL. When a new unit is selected press ENTER.

Pressing ENTER displays the following. Press ENTER to read flow.

Attach sensors	
REFLEX Sep	10.2

This informs the user of the mode of operation and the separation distance.

Pressing SCROLL takes the instrument into **SETUP SENSOR** mode.

SETUP SENSORS
 Mode REFLEX

Pressing ENTER will read flow.

l/m	0.00
l	0.00

When measuring flow there are only three keys that are active. **FUNCTION, RESTART** and **SCROLL.** (see also page 7)

The **Function** key when pressed in flow mode displays a range of information that will improve the performance of the instrument and will assist with the setting up of the unit.

The **Restart** key will at any point in the program display the start up message. This allows the user to restart the program from the beginning.

The **Scroll** key when pressed in flow mode will display the signal level and the mA output.

Pressed for a second time it will display the ERRORS PENDING (see page 16 - Error & Warning Messages). When pressed for a third time it will read flow.

FUNCTIONS

When the instrument is measuring flow, there are certain functions that the user can access. These functions are accessible by pressing the function key on the keypad then entering the password 2000.

The display will read the following. Select one of the options by using the scroll key and press ENTER to select.

FUNCTIONS	
Display	L/M
Setup 4-20mA	
Pulses/set point	
Cutoff m/s	0.05
Set zero flow	
Reset total flow	
Damping	5
Cal factor	1.000
Diagnostics	
Save and exit	

FUNCTIONS – Display

The display will show the following. Press ENTER to select.

Functions	
Display	L/M

By pressing ENTER then SCROLL the user is able to change the measuring units. When selected press ENTER. The units displayed will depend on whether a Flow meter or Heatmeter has been purchased. Energy options appear the list of flow units have been displayed. Press Enter when you have selected what you would like displayed. This is the same operation for both the Heatmeter and Flowmeter.

FUNCTIONS - Setup 4-20mA

If a Heatmeter is supplied there will be two 4-20mA outputs available for use. They can be set up separately to whatever output is required. When using the 4-20mA to monitor temperature it will only monitor the temperature difference and not the individual temperatures of the flow and return.

The display will show the following. Press ENTER to select.

Functions	
Setup 4-20mA	

The display will show the following. Scroll through each item and press ENTER to select.

SETUP 4-20MA	

mA out	0.00
Output	OFF
Units	L/M
Max.	1000
Min.	0.00
mA on error	22.0
Exit	

The display will show the following. Press Enter to select.

SETUP 4-20MA	
Output	OFF

This shows the user what the output is giving at any particular time. Press SCROLL to continue.

The display shows the following. Select the output required and press ENTER.

OUTPUT	
OFF	
4-20mA	
0-20mA	
0-16mA	

It is possible to choose between switching the output ON/OFF or selecting the output required by pressing SCROLL and ENTER.

SETUP 4-20MA	
Units	L/M

It is possible to set the output different from that on the display. For example the display may show gallons/minute but the output needs to be set up in m³/hour. When a Heatmeter is supplied the options will include kW, kCal/hr, MJ/hr, min, sec and temperature differential. Scroll through the options and press ENTER to select.

The display will show the following.

SETUP 4-20MA	
Max.	1000

This function allows the user to scale the 4-20mA. Press ENTER to select and enter your required maximum flow rate in the units selected. For example when the flow rate reaches the maximum set, the output will be 20mA. Press ENTER when complete.

The display will show the following.

SETUP 4-20MA	
Min.	000

The user is now required to enter the minimum flow rate required in the units selected. Press ENTER when complete.

The display will show the following.

SETUP 4-20MA	
mA on error	22

This gives an error output which would inform the user of loss of signal. This can be set to any figure between zero and 24mA, but defaults to 22mA. Press ENTER to select, enter the figure required and press ENTER.

The display will show the following.

SETUP 4-20MA	
Exit	

Press SCROLL to stay in the **SETUP 4-20mA** menu or ENTER to go back to the **FUNCTIONS** menu.

FUNCTIONS - Pulses/set point

The following will be displayed. Press ENTER to select.

FUNCTIONS	
Pulses/set point	

This gives the user a choice of using a pulse output or the set point facility. Pulse output and set point cannot be used at the same time.

Scroll through the following options. Press ENTER to select.

PULSES/SET POINT	
Units	L/M
Output	OFF
l/pulse	
Set point	
Exit	

The display shows the following. Use the scroll key to select units, press ENTER.

PULSES/SET POINT	
Units	L/M

At this point the user is able to select the units required by pressing ENTER. Scroll through the options required and press ENTER when selected.

The display will show the following. Press ENTER to select.

PULSES/SET POINT	
Output	OFF/PULSES/SET POINT

Note: The display will show the previous selection.

OUTPUT	
Off	
Pulses	
Set point	

Press SCROLL to select and then ENTER.

This facility allows the user to set the **Pulses/Set point** or switch it off altogether. Selecting **Off** and pressing ENTER will move the program to **Cutoff m/s**. Press SCROLL to select **Pulses** or **Set point** and press ENTER.

If **Pulses** were selected the display will show the following.

PULSES	
l/pulse	1000

This can be scaled to the users requirements up to a maximum of one pulse per second.
Or

SET POINT	
Set point	1000

The **Set point** can be set to the users requirements to trigger an alarm or indicator, when the flow has reached a minimum or maximum level.

The instrument defaults to 1000. This will be in the units selected previously. It can now be changed to the required amount by pressing ENTER. Enter the new amount then press ENTER.

The display now reads the following. Press ENTER to return to **FUNCTIONS**.

PULSES/SET POINT
Exit

FUNCTIONS - Cutoff m/s

The display will now show the following.

FUNCTIONS
Cutoff m/s

The instrument has a preset **CUTOFF** of 0.05m/sec, which has been programmed into the instrument. Micronics cannot guarantee measuring flows below this range because of instabilities in the measuring process. It is possible for the user to change or cancel this figure but Micronics cannot guarantee the performance below this. It is also possible to enter any figure up to a velocity of 1m/sec.

FUNCTIONS - Set Zero Flow

Press ENTER to select.

FUNCTIONS
Cutoff m/s

On some applications the instrument is capable of picking up noise which may show a small offset when in flow mode. This offset should be cancelled out which will increase the accuracy of the instrument.

Before this function is used you have to be sure that the flow has stopped completely. To set zero flow before the flow has stopped will result in an error message. This will occur when the flow is still above 0.25m/sec. This could mean that the flow has not totally stopped. Press SCROLL to answer NO and ENTER to answer YES.

The following is displayed.

FLOW > 0.25 m/s
Continue ?

If the flow is below 0.25 m/sec then the following will be displayed.

Stop the flow and
press ENTER

Follow the instructions on the display by pressing ENTER.

Zero flow set

Press ENTER

FUNCTIONS - Reset Total Flow

The display will now show the following.

FUNCTIONS
Reset total flow

This function resets the total Flow or Energy. If a Heatmeter was supplied it is possible to re-set the total Energy. Press ENTER.

The display will now ask the following.

RESET TOTAL FLOW
Are you sure?

Or

RESET TOTAL ENERGY
Are you sure?

Answer YES by pressing ENTER and NO by pressing SCROLL.

If you have answered YES the following will be displayed. Press SCROLL to continue.

RESET TOTAL FLOW
Total reset

If you have answered NO the following will be displayed. Press SCROLL to continue.

FUNCTIONS
Reset total flow

FUNCTIONS – Damping

The display will show the following.

FUNCTIONS
Damping 5

This option is used when flow readings are unstable due to turbulence caused by internal obstructions or bends etc. Damping or averaging can be used to make the readings more stable. It can be set to up-date the display between every 3 to 100 seconds. Press ENTER to select. Enter the time in seconds then press ENTER.

FUNCTIONS - Cal Factor

The display will show the following.

FUNCTIONS

Cal factor	1.000
------------	-------

This facility should never have to be used if the correct application data has been entered into the unit when being installed.

The calibration factor enables the instrument to be calibrated to any existing meter or flow rate. The transducers are always calibrated to work with the electronics supplied. If for any reason the transducers are damaged the new ones supplied will not have been calibrated with the electronics. The calibration factor could then be used to give the same reading as other transducers.

If the new reading is 4% higher than normal then entering 0.96 will reduce the flow reading by 4%. If the reading is 4% lower than normal, entering 1.04 would increase the reading by 4%. When the instrument is supplied it will always default to 1.00. If it has to be changed the new cal number will stay in the memory until changed again. Press ENTER to select. Enter new data and press ENTER.

FUNCTIONS - Diagnostics

The display will now read.

FUNCTIONS Diagnostics

Diagnostics is not an option for the user. The numbers displayed cannot be changed in any way and are only of benefit to Micronics engineers when testing the instrument or fault finding. Press SCROLL to continue.

FUNCTIONS - Save and Exit

The display now reads.

FUNCTIONS Save and exit

Press SCROLL to start at the beginning of the **FUNCTIONS** menu again or ENTER to save all the changes made and read flow.

ERROR and WARNING MESSAGES

E1:High Flow?

When the instrument is programmed the user is informed of the maximum flow rate that the instrument can measure. If this is exceeded the High flow message occurs.

It may be possible to get round these problems by using another set of transducers in another mode. This should not be necessary as the unit would have been supplied for a particular application with the correct transducers.

E2:No Flow Sig

This message appears when the two transducers cannot send or receive signals. This could happen

for a variety of reasons. Firstly check that all cables are connected, transducers are on the pipe correctly and at the correct separation distance. Check that there is couplant on the transducers.

This message may also appear when trying to measure a partially full pipe, aerated liquid or when the particulate content of that liquid is too high. The condition of the pipe being measured could also be a problem.

E3:HOT Fault (only applicable for the Heatmeter)

This message appears when the temperature probe on the feed pipe is not connected. Check the connections under the terminal lid.

E4:COLD Fault (only applicable for the Heatmeter)

This message appears when the temperature probe on the return pipe is not connected. Check the connections under the terminal lid.

WARNING MESSAGES

W1:Check Data

This message occurs when the application information has been entered incorrectly or the transducers have been attached to the wrong pipe size. This will cause the timing to be in error. The site data needs to be checked and the instrument reprogrammed.

W2:Timing Poor

Unstable signal timing or differing up/down stream times indicate that the liquid is aerated or pipe surface is of poor quality.

W3:Signals Poor

This warning appears when there is a signal lower than 25%. This could be due to the application or a poor quality pipe etc.

W4:mA (1) Over

The mA (1) output is over range when the Flow/Energy or Temperature differential is higher than the maximum mA range.. It is possible to re-scale the 4-20mA to be able to cope with the higher range.

W5:mA (2) Over

Only one 4-20mA output is available with the Flowmeter but both are available with the Heatmeter. Both 4-20mA outputs are set up in the same way when supplied.

W6:Pulse at Max

This message occurs when the pulses have exceeded the maximum setting. It is possible to re-scale the pulse output to cope with the higher flow rate.

APPLICATION NOTES

The ULTRAFLO 2000 is a "Transit Time" Ultrasonic flowmeter which has been designed to work with "Clamp On" transducers, thus enabling liquid flowing within a closed pipe to be measured accurately without the need for any mechanical parts to be inserted either through the pipe wall or protrude into the flow system.

The meter is controlled by a micro-processor containing a wide range of data which enables the instrument to measure flow in any pipe diameter from 13mm bore up to 5000mm, made of any material and over a wide range of operating temperatures.

The system operates as follows:

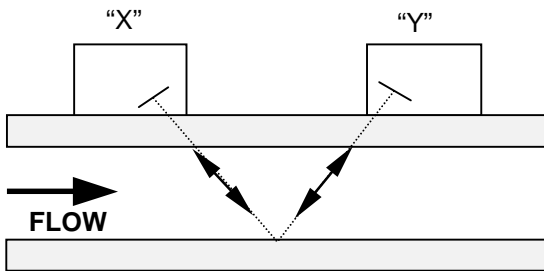

When ultrasound is transmitted from transducer "X" to transducer "Y" the speed at which the sound travels through the liquid is accelerated slightly by the velocity of the liquid. If sound is transmitted in the opposite direction from "Y" to "X" it is decelerated because it is travelling against the flow of the liquid. The difference in time taken to travel the same distance but in opposite directions is directly proportional to the flow velocity of the liquid.

Having measured the flow velocity and knowing the pipe cross-sectional area, the volumetric flow can be easily calculated. All of the calculations required to first determine the correct siting of the transducers and subsequently compute the actual flow are carried out by the microprocessor.

To measure flow, it is first necessary to obtain detailed information about each application, which is then programmed into the processor via the keypad. This information must be accurate otherwise flow measurement errors will occur.

Further having calculated the precise position at which the transducers must be clamped onto the pipe wall, it is equally important to align and separate the transducers accurately with respect to one another, as failing to do so will again cause errors in measurement.

Finally to ensure accurate flow measurement it is imperative that the liquid is flowing uniformly within the pipe and that the flow profile has not been distorted by any upstream or downstream obstructions.

To obtain the best results from the Ultraflo 2000 it is absolutely necessary that the following rules for positioning the transducers are adhered to and that the condition of the liquid and the pipe wall are suitable to allow transmission of the sound along its predetermined path.

Selecting A Meter Position

As the transducers with the Ultraflo 2000 are clamped to the outside surface of the pipe, the meter has no way of determining exactly what is happening to the liquid. The assumption therefore has to be made that the liquid is flowing uniformly along the pipe, either under fully turbulent conditions or under laminar flow conditions.

It is further assumed that the flow velocity profile is uniform for 360° around the pipe axis. The Ultraflo 2000 is normally supplied calibrated for use on turbulent flows but by adjustment of the **CAL FACTOR** the instrument can be used for laminar flow applications.

Figure 11

Figure 11 shows a uniform profile as compared to a distorted profile.

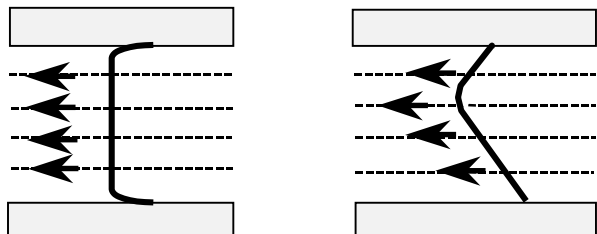

The difference between (a) and (b) is that the "Mean Velocity" of the flow across the pipe is different and the Ultraflo 2000 expects a uniform flow as in (a). The distorted flow in (b) will give measurement errors which cannot be predicted or compensated for.

Flow profile distortions result from upstream disturbances such as bends, tees, valves, pumps and other similar obstructions. To ensure a uniform profile the transducers must be mounted far enough away from any cause of distortion such that it no longer has an effect.

Figure 12

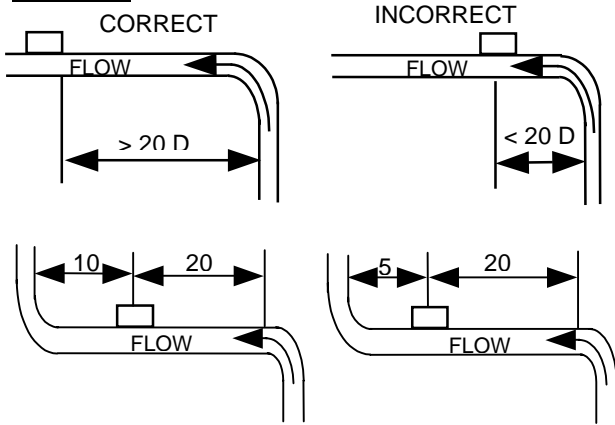

The minimum length of upstream straight pipe is 20 diameters and 10 diameters downstream which ensures that accurate results will be achieved. Flow measurements can be made on shorter lengths of straight pipe down to 10 diameters upstream and 5 diameters downstream, but when the transducers are sited this close to any obstruction errors can be considerable.

It is not possible to predict the amount of error as this depends entirely upon the type of obstruction and the configuration of the pipework. The message therefore is clear. Do not expect to obtain accurate results if the transducers are positioned closer than allowed to any obstruction that distorts the uniformity of the flow profile.

Examples of the effects of two different pipe configurations are shown in Figure 13.

Figure

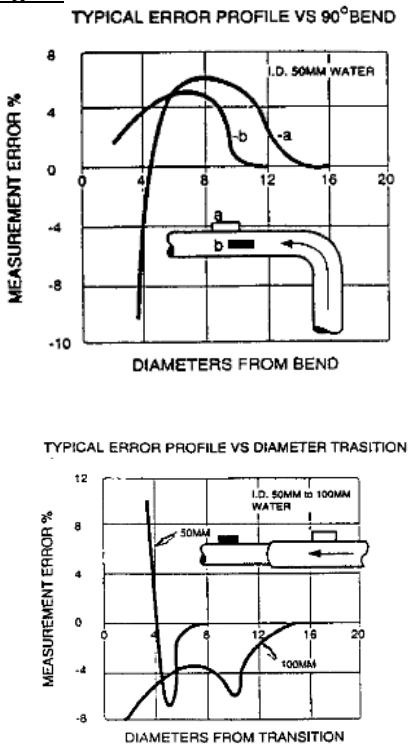

Mounting The Transducers

It will be impossible to achieve the accuracy of measurement specified for the Ultraflo 2000 if the transducers are not clamped to the pipe correctly and if the data - I.D., O.D., Temperature, Pipe Material are not accurate.

The transducers are supplied with a guide rail, the purpose of which is to ensure that the transducers are aligned accurately with the pipe axis and that the face of the sensor is tangential to the axis.

Apart from the correct positioning and alignment of the transducers, of equal importance is the condition of the pipe surface in the area under each of the transducers.

An uneven surface that prevents the transducers from sitting flat on the surface of the pipe can cause Signal Level and Zero Offset problems. The following procedure is offered as a guide to good practice with respect to positioning and mounting the transducers.

1. Select the site following the rules laid down on page 17.
2. Inspect the surface of the pipe to ensure it is free from rust and unevenness. Transducers can be mounted directly on painted surfaces as long as the surface is smooth and that the underlying metal surface is free from rust particles. On bitumen or rubber coated pipes the coating must be removed in the area under the transducers as it is preferable that the transducers are mounted directly on to base metal.
3. Transducers can be mounted on both Vertical or Horizontal pipe runs.

Figure 14 - Horizontal pipes

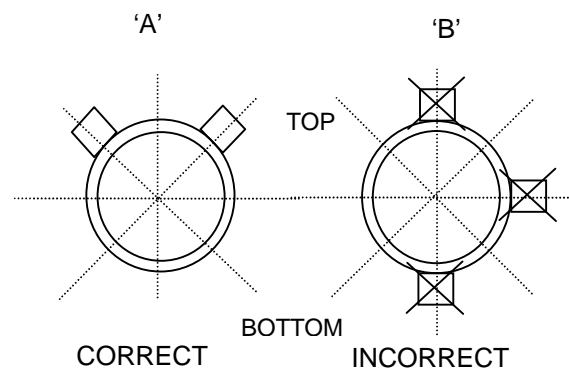

4. Apply interface couplant to the face of the transducers.

The amount of couplant used is extremely important particularly on pipes of less than 100mm bore. Use the syringe supplied with the instrument and apply couplant as shown.

On small pipes below 90mm the bead of grease used must be approximately 20mm long and 2mm maximum diameter. Using more grease will cause

wall signals to be generated which cause errors in measurement.

Figure 15

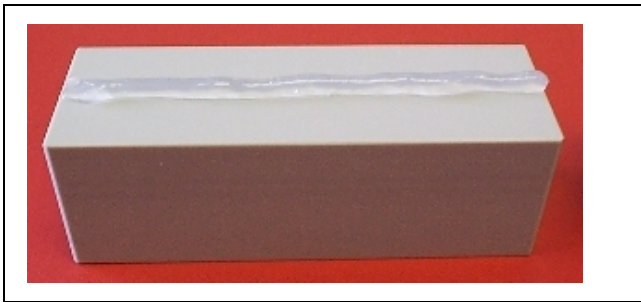

On Stainless Steel pipes the amount of couplant applied should never exceed the amount indicated in the examples above. For large plastic and steel pipes the amount of couplant applied is less critical however do not use more than is absolutely necessary.

5. Attach the guide rail assembly to the pipe so that it is perfectly parallel to the pipe axis.
6. When screwing the transducers on to the pipe surface use only enough force to ensure that the transducer is flat against the pipe surface and then lock in position.
7. Clamping the transducers in exactly the correct position is extremely important. The Ultraflo 2000 calculates the separation distance and the transducers must be positioned and clamped exactly at the distance specified.
8. Always use the couplant provided.

Liquid Conditions

Transit Time ultrasonic meters perform best on liquids that are totally free from entrained air and solids. With sufficient air in the system the Ultrasound beam can be attenuated totally and therefore prevent the instrument from working. Often it is possible to tell whether there is air in the system or not.

If a flow signal cannot be obtained a simple test to determine whether the flow is aerated involves cutting off the flow for a period of 10 - 15 minutes. During this time the air bubbles will rise to the top of the pipe and the flow signal should return.

When the flow signal has returned “Switch on” the flow and if sufficient entrained air is locked in the system it will very quickly disperse and kill the signal.

Propagation Velocity

To make a flow measurement using the Ultraflo 2000 on any liquid other than water it is necessary to know the propagation velocity in

metres/second, of the particular liquid. Micronics can supply this information.

Maximum Flow

The Ultraflo 2000 is normally supplied with hardware suitable for the specific application for which the instrument has been purchased. It is possible to use the instrument on a wide range of applications as long as the transducers will cope with the maximum velocity and temperature required.

Application Temperature

On any application with an operating temperature above or below ambient temperature, ensure that the transducers reach and are maintained at the application temperature before undertaking calibration.

When applying the transducers to low temperature pipes, do not allow the pipe surface to ice up between the transducer and the pipe wall.

Wherever possible insulate the transducers such that variations in ambient air temperature do not effect the relationship between the transducer and the liquid temperature.

The instrument automatically compensates for changes in application temperature over a range of approximately +/- 20°C.

FLOW RANGE

Figure 16

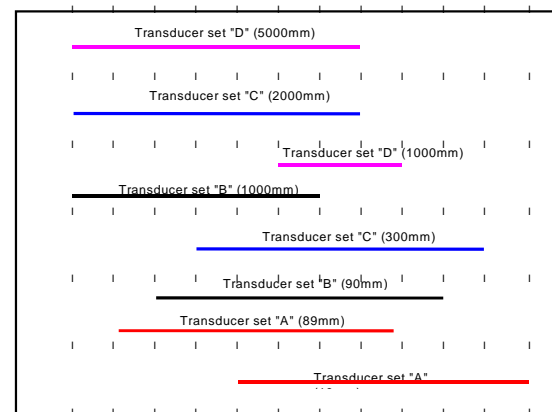

SPECIFICATION

ELECTRONIC ENCLOSURE:

Protection Class	IP67
Material	ABS
Dimensions	264 x 230 x 101 mm
Display	2 x 16 Character Super Twist LCD backlit
Keypad	IP67
Sensor Connections	TNC Coax Connectors
All Other Connections	IP65 Glands
Temperature Range	0°C to 50°C Operating -10°C to 60°C Storage

SUPPLY VOLTAGE:

Switchable	110–240 VAC ± 50/60 Hz Max. 5 watts 24 Volt DC
------------	---

FLOW OUTPUTS:

Flow Display	Volumetric Flow	m ³ , litres, gallons (Imperial and US)
	Flow Velocity	metres/sec, feet/sec
	Flow Rate	0.2...12 m/sec to 4 Significant Figures
	Total Flow	12 Digits
	Signal Level Indication	
	ERROR messages	
Analogue	4 - 20mA into 750 Ω	Opto isolated with user definable scaling
	Resolution	0.1% of full scale
Set Point or Pulse	Max. 1 pulse per second	User definable scaling

HEATMETER OPTIONS:

Display	Energy	kW, kCal/hr, MJ/hr,min,sec, kJ/hr,min,sec
Analogue	2 off 4-20mA	Opto isolated with user definable scaling
Pulse Output	Max. 1 pulse per second	User definable scaling
Temperature Sensors:	PT100	-20°C to +220°C
	Max. temp. differential	220°C

Pipe Sizes	Flow Velocity Range
------------	---------------------

‘A’	50 mm...89 mm	0.2 m/sec...4 m/sec (8 m/sec)
‘B’	90 mm...1000 mm	0.2 m/sec...8 m/sec (12 m/sec)
‘C’	300 mm...2000 mm	0.2 m/sec...4 m/sec (7 m/sec)
‘D’	1000 mm...5000 mm	0.2 m/sec...4 m/sec (7.5 m/sec)

Frequency:	1MHz, 2MHz, 0.5MHz
Flow Transducer Protection:	Standard: IP65
Flow Transducer Cables:	50 Ohm Coax Cable
Flow Transducer Cable Length:	3 metres Standard - Optional up to 200 metres
Flow Transducer Temp. Range:	-20°C to +200°C (‘D’ only up +80°C)

ACCURACY:

± 1...2% of reading or ± 0.02 m/sec, whichever is the greater.
Specification assumes turbulent flow profile with Reynolds numbers above 4000.

REPEATABILITY:

± 0.5% with unchanged transducer position.

PIPE MATERIALS:

Any sonic conducting medium such as Carbon Steel, Stainless Steel, Copper, UPVC, PVDF, Concrete, Galvanised Steel, Mild Steel, Glass, Brass. Includes lined pipes – Epoxy, Rubber Steel, Plastic.

Micronics reserve the right to alter any specification without notification.

HEATMETER INSTRUCTIONS

1. **Installation**

Connect the flow transducers to the instrument as described in the HARDWARE section of this manual. Note that the Ultraflo must read positive flow otherwise the energy displayed will read zero.

Attach the temperature probes to the outside of the flow and return pipes. Use the stainless steel banding to attach the temperature probe. Heat sink compound should be applied between the probe and pipe for better heat transfer. Lagging should then be wrapped over the temperature probe itself to stabilise the temperature.

One temperature probe should be attached to the feed pipe as the HOT SENSOR and the other is attached to the return pipe as the COLD SENSOR.

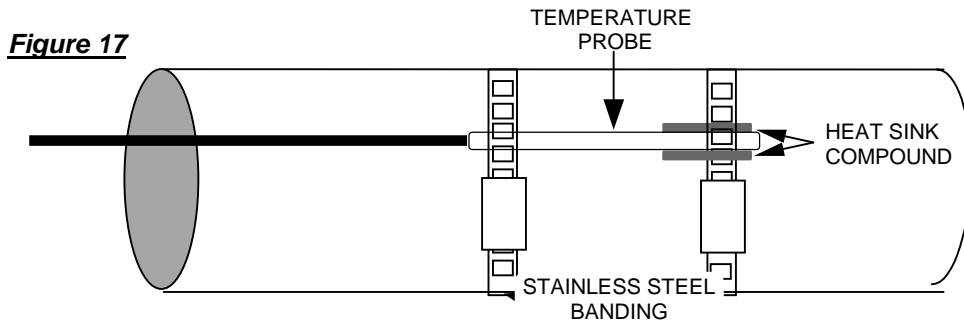

Remove the terminal lid and connect the temperature probes' making sure the power is turned off. Connect the HOT sensor to the terminal marked HOT (Pins 5,6,7) and the COLD sensor to the terminal marked COLD (Pins 8,9,10). **A reversed temperature connection will make the measured energy zero.**

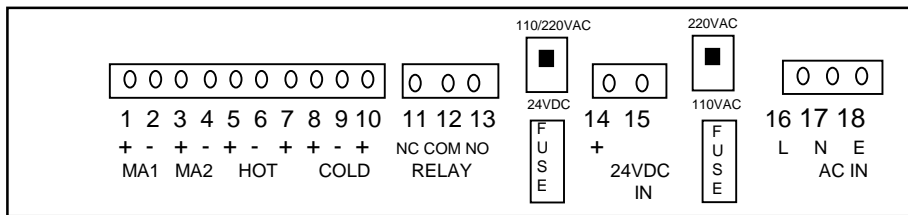

The WHITE core from each temperature probe must always be connected to the negative (Pins 6 and 9). The other two cores on each temperature probe connect to either of the positive terminals (Pins 5, 7 and Pins 8,10). **Always remember to earth the PT100 probes using the screen core. The PT100 are subject to interference from power sources such as, pumps and invertors and any electrical equipment. The interference will cause an error in the measurement of temperature.**

2. **Operation**

Connect power to the instrument and wait for a few seconds.

1. Follow the **Quick Start** menu on page 8 to read flow. Note that if the fluid selected is not water, the user will be prompted for the SHC (specific heat capacity) and the density relative to water (specific gravity). For water @ 20°C the SHC is 4.2 kJ/m³ and the density is 996kg/m³. To calculate the SHC figure to enter into the unit find the SHC of the liquid being measured in kJ/kg K and divide by 4.2 kJ/kg K. Now enter this figure into the unit.
2. To calculate the relative density, find the density in kg/m³ and divide by the density of water @ 20°C (996 kg/m³). Now enter this number into the unit. The SHC and Density figures are usually available from your supplier.
3. Select the Energy units required when setting up the display or outputs from the **FUNCTION** menu on page 13. Scroll through the options and press ENTER to select.
4. It is now possible to set either of the two 4-20mA outputs for Flow/Energy or Temperature differential as described in **FUNCTIONS** on page 13.

CE MARKING

The Ultraflo 2000 has been tested and found to conform to EN50081 - 1 Emission Standards and EN50082 - 1 Immunity Standards.

The tests were conducted by AQL - EMC Ltd, of 16 Cobham Road, Ferndown Industrial Estate, Wimborne, UK BH21 7PG.

The unit was tested with all cables as supplied of a maximum length of 3m. While the operation of the unit may not be affected by the use of longer cables, Micronics can make no statement about conformance to the above standards when these cables are in use.

MANUFACTURERS WARRANTY

The Ultraflo 2000 Ultrasonic liquid flow meter is guaranteed by MICRONICS to be free from defects in materials and workmanship for a period of one year from the date of shipment to the original customer, provided that the equipment has been installed and used in the manner described in this User's Manual.

Fuses and sensor cables are not included in this warranty.

Repair or replacement, at MICRONICS option, will be made without charge at its factory during the warranty period.

If any problems develop, take the followings steps:

- 1) Notify MICRONICS or the Distributor from whom you purchased the meter giving full details of the problem. Be sure to include the model and serial numbers of your flow meter. You will then receive service data and/or shipping instructions, depending on your problem.
- 2) If you are instructed to send your meter back to the factory, please send it prepaid to the authorised repair station, as indicated in the shipping instructions.

The warranty of the ULTRAFLO 2000 Ultrasonic Liquid Flow meter by MICRONICS is limited to those stated above and MICRONICS will not be liable for anything beyond this.

Document Number 001 - 150
Software Version: v1.12