



ROOTS Meters & Instruments

DATA SHEET

G160-4" Meter

Temperature Range	deg.C	-40 to +60
Base Rating (Qmax)	m ³ /h	250
Max. Operating Pressure	bar	16
Leak Test (1.1 x MOP)	bar	17.6
Static Test (1.5 x MOP)	bar	24
Rangeability +/- 1%	ratio	70:1
Rangeability +/- 2%	ratio	125:1
Start Rate	m ³ /h	0.1510
Stop Rate	m ³ /h	0.0960
Flow Rate @ 1.25mbar	m ³ /h	230
Avg. Differential, 100% Flow	mbar	1.73
Max. Pressurisation Rate	kPa/sec	35
Max. Operating Speed	rpm	1500
Gear Ratio	ratio	360.64
Displaced Volume/Revolution	dm ³	2.77
Drive Rate	m ³ /rev	1.0
Min. Odometer Reading	m ³ /h	0.02
Odometer Turnover	yrs	4.57
Nominal Pipe Size	mm	100
Flange to Flange	mm	241
Flange Connection	DIN	DN100 PN16
Bolts per Flange	Qty	8
Bolt Size	mm	M16 x 40
Flange Bolt Hole Depth	mm	24
Bolt Torque: Lubricated/Non-Lub.	N-m	74/81
Oil Capacity (Side Inlet)	ml	100
Oil Capacity (Top Inlet)	ml	645

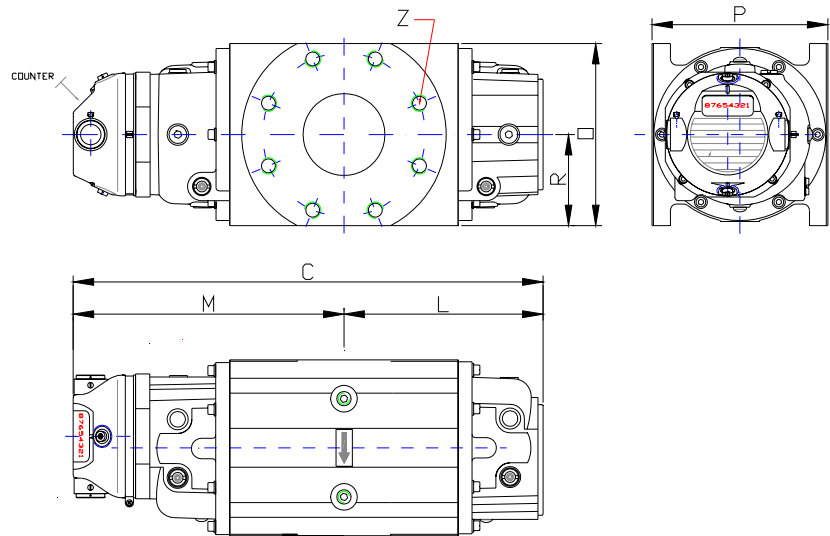
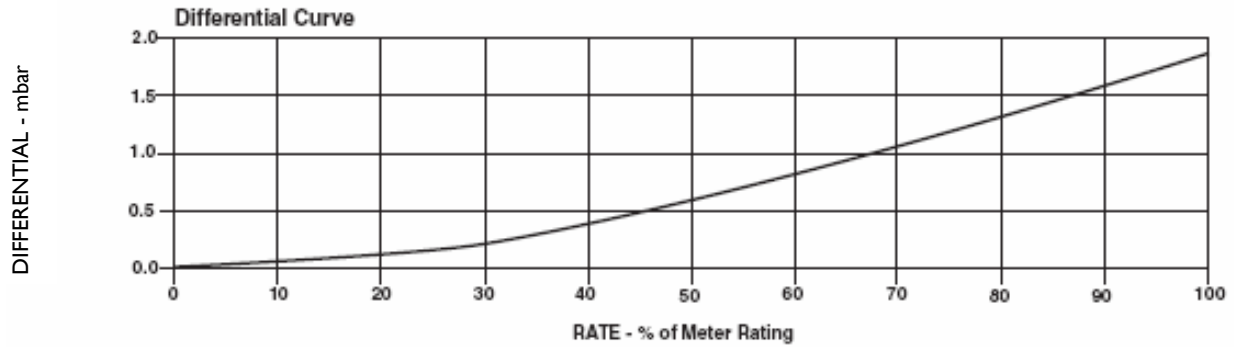
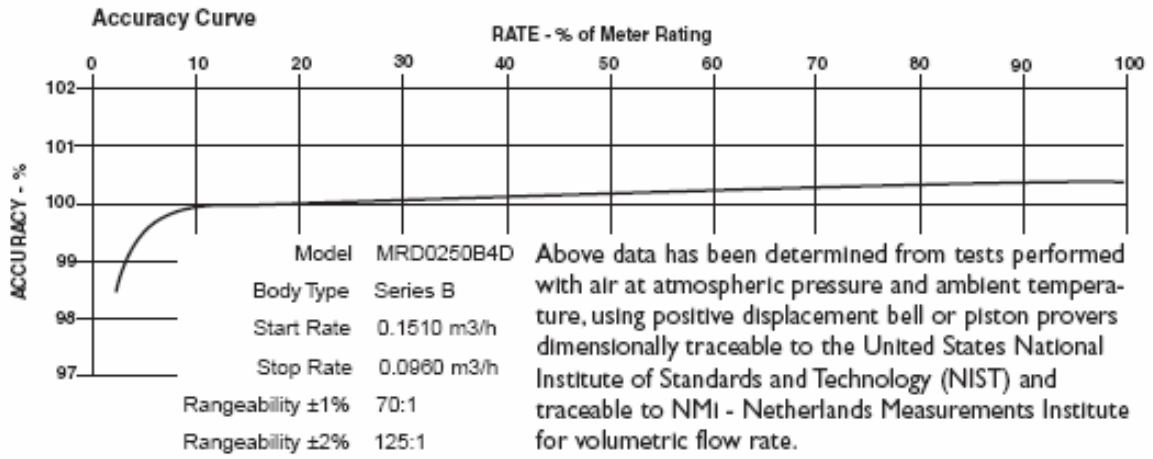

Meter Size	C mm	L mm	M mm	O mm	P mm	R mm	Z	Flange	Weight Kg
9MT-4	485	205	280	226	241	113	8	DN100	28



Roots Meters & Instruments

DMD-ROOTS

DI UK Limited
Dresser Inc

Dresser House · East Gillibrands Estate · Skelmersdale · WN8 9TU · England
 Telephone + (0)1695 52600 · Telefax + (0)1695 52610