



ROOTS Motors & Instruments

DATA SHEET

8CT – G16

Temperature Range	deg.C	-40 to +60
Base Rating (Qmax)	m ³ /h	25
Max. Operating Pressure	bar	16
Leak Test (1.1 x MOP)	bar	17.6
Static Test (1.5 x MOP)	bar	24
Rangeability +/- 1%	ratio	28:1
Rangeability +/- 2%	ratio	50:1
Start Rate	m ³ /h	0.0790
Stop Rate	m ³ /h	0.0575
Flow Rate @ 1.25mbar	m ³ /h	25
Avg. Differential, 100% Flow	mbar	0.54
Max. Pressurisation Rate	kPa/sec	35
Max. Operating Speed	rpm	1990
Gear Ratio	ratio	476.16
Displaced Volume/Revolution	dm ³	0.21
Drive Rate	m ³ /rev	0.1
Min. Odometer Reading	m ³ /h	0.002
Odometer Turnover	yrs	4.5
Nominal Pipe Size	mm	50
Flange to Flange	mm	171
Flange Connection	DIN	DN50 PN16
Bolts per Flange	Qty	4
Bolt Size	mm	M16 x 40
Flange Bolt Hole Depth	mm	23.8
Bolt Torque: Lubricated/Non-Lub.	N-m	74/81
Oil Capacity (Side Inlet)	ml	24
Oil Capacity (Top Inlet)	ml	89

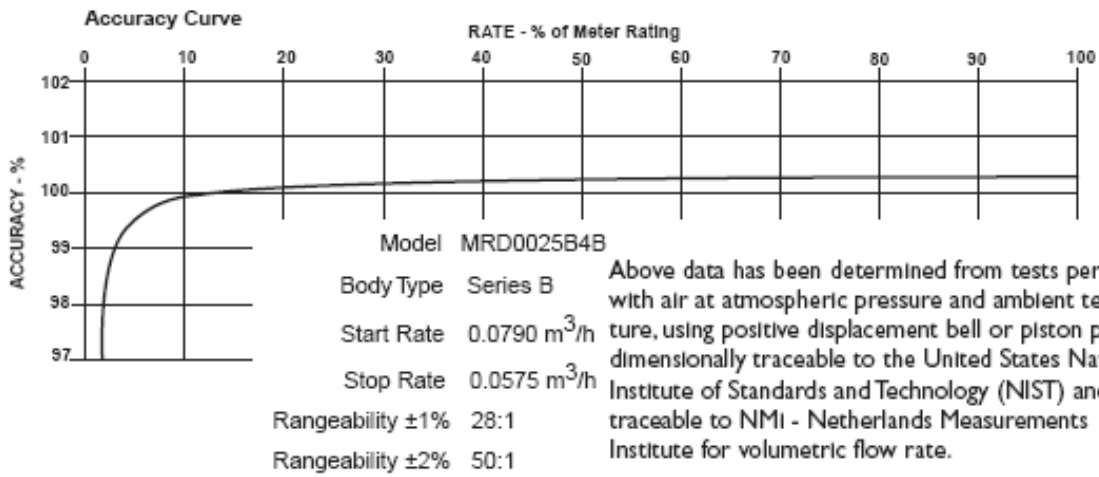

DIFFERENTIAL - mbar

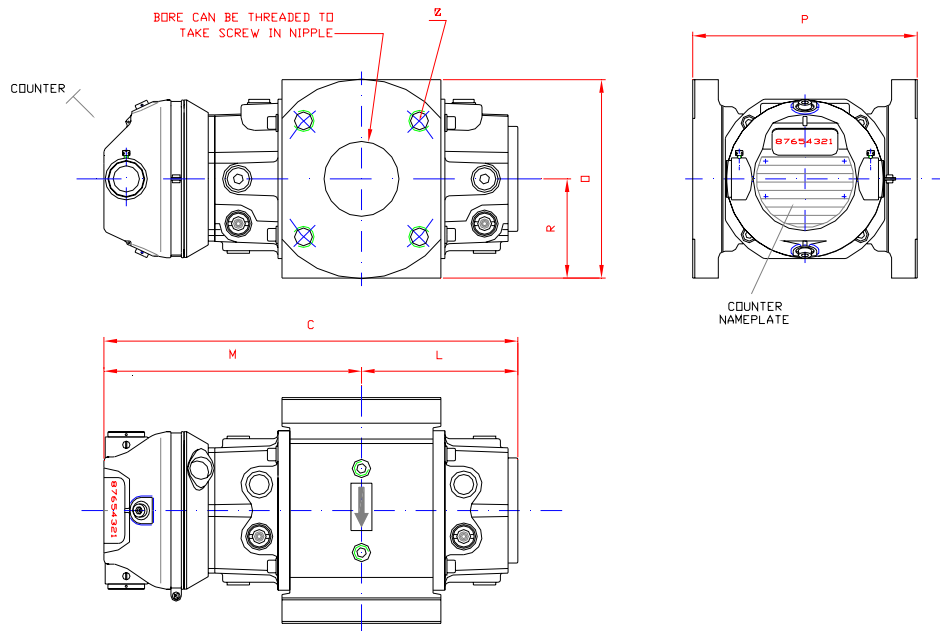
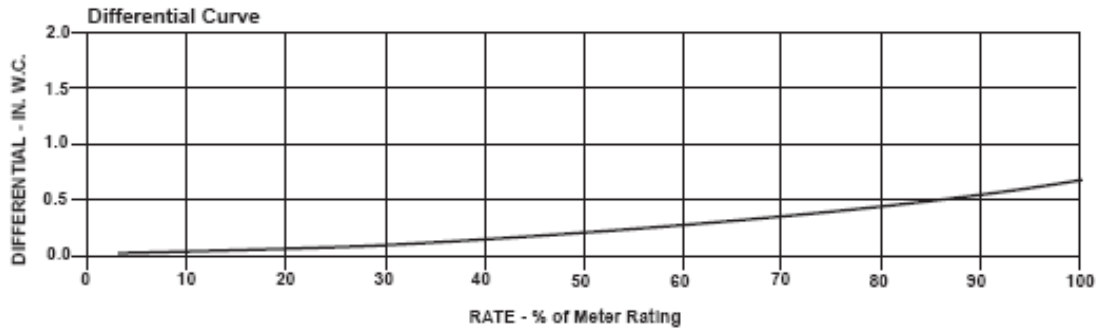

Meter Size	C mm	L mm	M mm	O mm	P mm	R mm	Z	Flange	Weight Kg
8CT	316	119	197	152	171	76	4	DN50	8



**Natural Gas Solutions
DI UK Limited**

Dresser House, Gillibrands Road, Skelmersdale, Lancashire, United Kingdom. WN8 9TU
Office: +44 1695 52600 Fax: +44 1695 52610
www.dresser.com