

Energy Management Energy Analyzer Type EM24 DIN



- Dimensions: 4-DIN modules
- Protection degree (front): IP50
- RS485 serial output (on request) (MODBUS-RTU), iFIX SCADA compatibility
- Dupline communication capability (DP option)
- Application adaptable display and programming procedure (Easyprog function)
- Easy connections management
- MID "annex MI-003" (Measuring Instruments Directive) compliant

Product Description

Three-phase energy analyzer with built-in configuration joystick and LCD data displaying; particularly indicated for active and reactive energy metering and for cost allocation. Housing for DIN-rail mounting with IP50 (front) protection degree. Direct connection up to 65A and by means of external current and potential trans-

formers. Moreover the meter can be provided with digital outputs that can be either for pulse proportional to the active and reactive energy being measured or for alarm outputs. In alternative the RS485 communication port and 3 digital inputs or Dupline port and 3 digital inputs are available as an option.

- Class 1 (kWh) according to EN62053-21
- Class B (kWh) according to EN50470-3
- Class 2 (kvarh) according to EN62053-23
- Accuracy ± 0.5 RDG (current/voltage)
- Energy analyzer
- Instantaneous variables readout: 4 DGT
- Energies/gas/water readout: 7+1 DGT
- System variables: VLL, VLN, Admd max, VA, VAdmd, VAdmd max, W, Wdmd, Wdmd max, var, PF, Hz, Phase-sequence.
- Single phase variables: VLL, VLN, A, VA, W, var, PF
- Energy measurements: total and partial kWh and kvarh or based on 4 different tariffs; single phase measurements
- Gas, cold water, hot water, kWh remote heating measurements
- Hour counter (6+2 DGT)
- TRMS measurements of distorted sine waves (voltages/currents)
- Self power supply (AV0-AV2-AV9 inputs)
- Auxiliary power supply (AV5-AV6 inputs)
- 3 digital inputs for tariff selection, DMD synch or gas/water (hot-cold) and remote heating metering (on request)
- 2 digital outputs for pulses or for alarms or as a mix of them (on request)

How to order **EM24 DIN AV5 3 X O2 X**

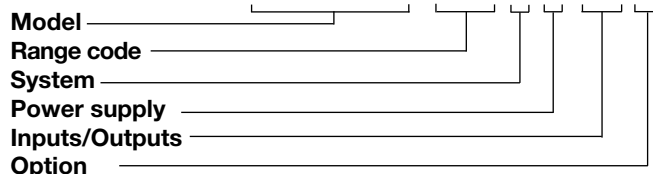

Type Selection

Range codes	System	Inputs/Outputs	Power supply
AV5: 400V _{LL} AC - 1/5 (10)A (CT connection) (*)	1: 1-phase, 2-wire; 3-phase, 3-wire;	XX: none (*)	X: Self power supply (See "Power supply specifications") (*)
AV6: 120V _{LN} /208V _{LL} AC - 1/5(10)A (VT/PT and CT connections) (*)	3-phase, 4-wire balanced load (**)	O2: dual open collector type (dual pulse or one pulse + one alarm or dual alarm) (*)	L: 18 to 60VAC/DC (48 to 62Hz) (**)
AV0: 120V _{LN} /208V _{LL} AC -10(65)A (direct connection)(**)	3: balanced and unbalanced load: 3-phase, 4-wire; 3-phase, 3-wire;	R2: dual relay type (functions as per "O2") (**)(°)	D: 115/230 VAC (48 to 62Hz) (*)
AV2: 133-230V _{LN} AC 230-400V _{LL} AC 10(65)A (direct connection) (**)	2-phase, 3-wire; 1-phase, 2-wire (*)	XS: RS485 port (**)	Note: "L" and "D" power supplies only for AV5 and AV6 inputs; "X" power supply only for AV0, AV2 and AV9 inputs.
AV9: 400V _{LL} AC - 10(65)A (*) (direct connection)	Options	IS: 3 digital inputs for tariff selection or Gas / water / remote heating metering plus RS485 port (*)	
	X: none (*)	DP: Dupline port plus 3 digital inputs for Gas / water / remote heating metering (°)	
	P: "Annex B" of MID (EC type certificate)		

(*) as standard.

(**) on request.

(°) not available if the range code is "AV2".

(°) available if the range code is either "AV2" or "AV5".

Input specifications

Rated inputs	System type: 3-phase Galvanic insulation by means of built-in CT's (AV5 and AV6 models). By direct connection (AV0, AV2 and AV9)	Type	LCD, h 7mm
Current type	AV5 and AV6: 1/5(10)A AV0: 10(65)A; AV2: 10(65)A; AV9: 10(65)A	Instantaneous variables read-out Energies	4 DGT Imported Total/Partial/ Tariff: 7+1DGT or 8DGT; Exported Total/Partial/ Tariff: 6+1DGT or 7DGT (with “-“ sign)
Current range (by CT)	AV5: 400 VLL	Overload status	EEEE indication when the value being measured is exceeding the “Continuous inputs overload” (maximum measurement capacity)
Current range (direct)	AV0: 120VLN/208 VLL AV2: 230/400 VLL AV9: 400 VLL	Max. and Min. indication	Max. instantaneous variables: 9999; energies: 9 999 999.9 or 99 999999. Min. instantaneous variables: 0.000; energies 0.0
Voltage	AV6: 120VLN/208 VLL		
Voltage			
Voltage by VT/PT			
Accuracy (Display + RS485) (@25°C ±5°C, R.H. ≤60%, 48 to 62Hz)	Ib: see below, Un: see below		
AV5 model	In: 5A, I _{max} : 10A; Un: 160 to 480VLN (277 to 830VLL)	LEDs	Red LED (Energy consumption)
AV6 model	In: 5A, I _{max} : 10A; Un: 40 to 144VLN (70 to 250VLL)	AV5, AV6 models	0.001 kWh/kvarh by pulse if CT ratio by VT ratio is ≤7; 0.01 kWh/kvarh by pulse if CT ratio x VT ratio is > 7.1 ≤ 70.0; 0.1 kWh/kvarh pulse if CT ratio x VT ratio is > 70.1 ≤ 700.0; 1 kWh/kvarh by pulse if CT ratio x VT ratio is > 700.1;
AV0 model	Ib: 10A, I _{max} : 65A; Un: 113 to 265VLN (196 to 460VLL)	AV0, AV2, AV9 models	0.001kWh/kvarh by pulse 16Hz, according to EN50470-3
AV2 model	Ib: 10A, I _{max} : 65A; Un: 184 to 276VLN (318 to 480VLL)	Max frequency	
AV9 model			
Current			
AV5, AV6 models	From 0.002I _n to 0.2I _n : ±(0.5% RDG +3DGT) From 0.2I _n to I _{max} : ±(0.5% RDG +1DGT).	Measurements	See “List of the variables that can be connected to:”
AV0, AV2, AV9 models	From 0.004I _b to 0.2I _b : ±(0.5% RDG +3DGT) From 0.2I _b to I _{max} : ±(0.5% RDG +1DGT).	Method	TRMS measurements of distorted wave forms.
Phase-neutral voltage	In the range Un: ±(0,5% RDG +1DGT)	Coupling type	Direct for AV0, AV2 and AV9 models. By means of external CT's for AV5 and AV6
Phase-phase voltage	In the range Un: ±(1% RDG +1DGT)		
Frequency	±0.1Hz (45 to 65Hz)	Crest factor	I _b 10A ≤4 (91A max. peak) I _n 5A ≤3 (15A max. peak)
Active and Apparent power	±(1%RDG +2DGT)	Current Overloads	
Power Factor	±[0.001+1%(1.000 - “PF RDG”)]	Continuous	1/5(10) A: 10A, @ 50Hz 10(65) A: 65A, @ 50Hz
Reactive power	±(2%RDG +2DGT)	For 500ms	1/5(10) A: 200A, @ 50Hz
Active energy	Class 1 according to EN62053-21 and MID Annex MI-003 Class B according to EN50470-3	For 10ms	10(65) A: 1920A max, @ 50Hz
Reactive energy	Class 2 according to EN62053-23	Voltage Overloads	
AV5, AV6 models	In: 5A, I _{max} : 10A; 0.1 In: 0.5A, Start up current: 10mA	Continuous	1.2 Un
AV0, AV2, AV9 models	Ib: 10A, I _{max} : 65A; 0.1 Ib: 1.0A Start up current: 40mA	For 500ms	2 Un
Energy additional errors		Input impedance	
Influence quantities	According to EN62053-21, EN50470-3, EN62053-23	208VL-L (AV6) 208VL-L (AV0)	>1600KΩ Refer to “Power Consumption”
Temperature drift	≤200ppm/°C	230/400VL-L (AV2)	Refer to “Power Consumption”
Sampling rate	1600 samples/s @ 50Hz 1900 samples/s @ 60Hz	400VL-L (AV5) 400VL-L (AV9)	>1600KΩ Refer to “Power Consumption”
Display refresh time	750 ms	1/5(10)A (AV5-AV6) 10(65)A (AV0-AV2-AV9)	< 0.3VA < 4VA
Display	3 lines (1 x 8 DGT; 2 x 4 DGT)	Frequency	45 to 65 Hz
		Joystick	For variable selection and programming of the instrument working parameters

Output specifications

<p>Digital outputs</p> <p>Pulse type</p> <p>Number of outputs</p> <p>Type</p> <p>Pulse duration</p> <p>Alarm type</p> <p>Number of outputs</p> <p>Alarm modes</p> <p>Set-point adjustment</p> <p>Hysteresis</p> <p>On-time delay</p> <p>Output status</p> <p>Min. response time</p> <p>Note</p>	<p>Up to 2, independent. Programmable from 0.001 to 10.00kWh/kvarh by pulse.</p> <p>Outputs connectable to the energy meters (kWh/kvarh) $\geq 100\text{ms} < 120\text{msec}$ (ON), $\geq 120\text{ms}$ (OFF), according to EN62053-31</p> <p>Up to 2, independent</p> <p>Up alarm, down alarm (see the table "List of the variables that can be connected to")</p> <p>From 0 to 100% of the display scale</p> <p>From 0 to full scale</p> <p>0 to 255s</p> <p>Selectable; normally de-energized or normally energized</p> <p>$\leq 700\text{ms}$, filter excluded, set-point on-time delay: "0 s"</p> <p>The 2 digital outputs can also work as a dual pulse output, dual alarm output, one pulse output and one alarm output.</p>	<p>Note</p> <hr/> <p>RS485</p> <p>Type</p> <p>Connections</p> <p>Addresses</p> <p>Protocol</p> <p>Data (bidirectional)</p> <p>Dynamic (reading only)</p> <p>Static (reading and writing)</p> <p>Data format</p> <p>Baud-rate</p> <p>Driver input impedance</p> <p>Insulation</p>	<p>The meters equipped with the relay outputs ("AV0" and "AV9" models with "R2" option) work even if VL3 is missing (VL1, VL2 and neutral have to be available)(see table "working mode notes")</p> <hr/> <p>Multidrop, bidirectional (static and dynamic variables)</p> <p>2-wire</p> <p>Max. distance 1000m</p> <p>247, selectable by means of the front joystick</p> <p>MODBUS/JBUS (RTU)</p> <p>System and phase variables: see table "List of variables..."</p> <p>All the configuration parameters.</p> <p>1 start bit, 8 data bit, no parity, 1 stop bit</p> <p>4800, 9600 bit/s</p> <p>1/5 unit load</p> <p>Maximum 160 transceivers on the same bus.</p> <p>By means of optocouplers, 4000 VRMS output to measuring input, 4000 VRMS output to power supply input.</p>
<p>Static output</p> <p>Purpose</p> <p>Signal</p> <p>Insulation</p>	<p>For pulse output or alarm output</p> <p>V_{ON} 1.2 VDC/ max. 100 mA</p> <p>V_{OFF} 30 VDC max.</p> <p>By means of optocouplers, 4000 VRMS output to measuring inputs, 4000 VRMS output to power supply input.</p>	<p>Note:</p>	<p>The meters equipped with the communication port ("AV0" and "AV9" models with "XS" and "IS" options) work even if VL3 is missing (VL1, VL2 and neutral have to be available)(see table "working mode notes")</p>
<p>Relay output</p> <p>Purpose</p> <p>Type</p> <p>Insulation</p>	<p>For alarm output or pulse output</p> <p>Relay, SPST type</p> <p>AC 1-5A @ 250VAC</p> <p>DC 12-5A @ 24VDC</p> <p>AC 15-1.5A @ 250VAC</p> <p>DC 13-1.5A @ 24VDC</p> <p>4000 VRMS output to measuring input</p> <p>4000 VRMS output to power supply input.</p>		

Dupline specifications

Counters Used Dupline function Number of counters Counter range Used channels Multiplexer Reset Value Counter reset Available counters	Multiplexer for counter values 6 per instrument 128 per network 0... 99 999 999 B to F B2 to B8 B1 C1 to F8 Enable/disable function for all the counters kWh tot, -kWh tot, kvarh tot, -kvarh tot, kWh t1, kWh t2, kWh L1, kWh L2, kWh L3, counter dig. in. 1, counter dig. in. 2, counter dig. in. 3, hour counter.	Available variables	variables) M1 to N8 (4 th group of 16 variables) O1 to P8 (5 th group of 16 variables) All, except for the “max” variables
Analogue variables Used Dupline function Number of variables	Multiplexer for analogue values 8 per instrument 80 per network	Synchro/Tariff input Used Dupline functions Used channels Working mode	Monostable (push-button) Realtime A5 Selectable: • none • Wdmd synchronization • total and partial energy meter (kWh, kvarh) managed by time periods (t1-t2).
Dupline data format Full scale value Used channels Multiplexer Value	3 1/2 DGT BCD Selectable from 1.999 to 1999M depending on the number of variables A1 to A4 G1 to H8 (1 st group of 16 variables) I1 to J8 (2 nd group of 16 variables) K1 to L8 (3 th group of 16	Alarms Used Dupline function Used channels Number of alarms Alarm modes Set-point adjustment Hysteresis On-time delay Output status Available variables	Monostable (push-button) Selectable (A1 to P8). No control that the selected channels are not used for counters or analog variables. 2 per instrument Up alarm, down alarm (see the table “List of the variables that can be connected to”) From 0 to 100% of the display scale From 0 to full scale 0 to 255s Normally energised All, except for the “max” variables

Digital input specifications

Number of inputs Input frequency Prescaler adjustment Contact measuring voltage Contact measuring current Input impedance Contact resistance Working modes (DP version excluded)	3 20Hz max, duty cycle 50% From 0.1 to 999.9 m ³ or kWh per pulse 5VDC +/- 5% 10mA max 680Ω ≤100Ω, closed contact ≥500kΩ, open contact Selectable: • total and partial energy meters (kWh and kvarh) without digital inputs; • total and partial energy meters (kWh and kvarh) managed by time periods (t1-t2-t3-t4), W dmd synchronisation (the synchronisation is made every time the tariff changes) and GAS (m ³) or WATER (hot-cold m ³) or remote heating (kWh) meters; • total and partial energy meters (kWh and kvarh)	Working modes (DP version only) Note Insulation	managed by time periods (t1-t2), W dmd synchronisation (the synchronisation is made independently from the tariff selection) and GAS (m ³) or WATER (hot-cold m ³) or remote heating (kWh) meters; • total energy (kWh, kvarh) and GAS, WATER (hot-cold m ³) and remote heating meters (3 choices only). Selectable: • GAS (m ³) or WATER (hot-cold m ³) or remote heating (kWh) meters The energy metering is only made by means of the analogue inputs. By means of optocouplers, 4000 VRMS digital inputs to measuring inputs, 4000 VRMS digital inputs to power supply input.
------------------------------------------------------------------------------------------------------------------------------------------------------------------------------------------------------------------	---------------------------------------------------------------------------------------------------------------------------------------------------------------------------------------------------------------------------------------------------------------------------------------------------------------------------------------------------------------------------------------------------------------------------------------------------------------------------------------------------------------------------------------------------------------------------------------------------------	------------------------------------------------------------------	------------------------------------------------------------------------------------------------------------------------------------------------------------------------------------------------------------------------------------------------------------------------------------------------------------------------------------------------------------------------------------------------------------------------------------------------------------------------------------------------------------------------------------------------------------------------------------------------------------------------------------------------------------------

Software functions

Password	Numeric code of max. 4 digits; 2 protection levels of the programming data: Password "0", no protection	Filter	0 to 100% of the input display scale
1st level	Password "0", no protection	Operating range	1 to 32
2nd level	Password from 1 to 9999, all data are protected	Filtering coefficient	Measurements, serial output (fundamental variables: V, A, W and their derived ones).
System selection		Filter action	
System 3-Pn unbalanced load	3-phase (4-wire)	Displaying	Up to 3 variables per page (see « Display pages »)
System 3-P unbalanced load	3-phase (3-wire)		8 different set of variables available (see « Display pages ») according to the application being selected
System 3-P1 (only AV5 and AV6) balanced load	3-phase (3-wire) one current and 3-phase to phase voltage measurements	Reset	
	3-phase (4-wire) one current and 1-phase (L1) to neutral voltage measurement	By means of the front joystick:	
System 2-P	2-phase (3-wire)	- dmd and dmd max;	
System 1-P	1-phase (2-wire)	- total energies (kWh and kvarh) and gas/water;	
		- partial energies and tariffs: kWh, kvarh	
Transformer ratio		Easy connection function	
VT (PT)	1.0 to 999.9 / 1000 to 6000 (only AV5 and AV6)	AV0, AV2 and AV9 models	Automatic phase sequence detection with current and voltage synchronisation.
CT	1.0 to 999.9 / 1000 to 9999 / 10.00k to 60.00k (only AV5 and AV6). The maximum power being measured cannot exceed 210 MW (calculated as maximum input voltage and current, see the "Accuracy" paragraph before). The maximum VT by CT ratio is 48600. For MID complaint applications the maximum power being measured is 25MW.	AV5-AV6-AV0-AV2-AV9 models	For all the display selections, both energy and power measurements are independent from the current direction. The displayed energy is always "imported" with the only exception of "F" and "H" types (see "display pages" table). For those latter selections the energies can be either "imported" or "exported" depending on the current direction.

General specifications

Operating temperature	-25°C to +55°C (-13°F to 131°F) (R.H. from 0 to 90% non-condensing @ 40°C) according to EN62053-21, EN50470-1 and EN62053-23	Dielectric strength	4000 VRMS for 1 minute
Storage temperature	-30°C to +70°C (-22°F to 158°F) (R.H. < 90% non-condensing @ 40°C) according to EN62053-21, EN50470-1 and EN62053-23	Noise rejection CMRR	100 dB, 48 to 62 Hz
Installation category	Cat. III (IEC60664, EN60664)	EMC	According to EN62052-11
Insulation (for 1 minute)	4000 VRMS between measuring inputs and power supply 4000 VRMS between power supply and RS485/digital output	Electrostatic discharges	15kV air discharge
		Immunity to irradiated	Test with current: 10V/m from 80 to 2000MHz
		Electromagnetic fields	Test without any current: 30V/m from 80 to 2000MHz
		Burst	On current and voltage measuring inputs circuit: 4kV
		Immunity to conducted disturbances	
		Surge	10V/m from 150KHz to 80MHz
		Radio frequency suppression	On current and voltage measuring inputs circuit: 4kV; on "L" auxiliary power supply input: 1kV According to CISPR 22



General specifications (cont.)

Standard compliance Safety	IEC60664, IEC61010-1 EN60664, EN61010-1 EN62052-11	Cable cross-section area AV5-AV6 models	Min./Max. screws tightening torque: 0.4 Nm / 0.8 Nm
			Metrology
Pulse output Approvals	DIN43864, IEC62053-31 CE, PTB MID according to "annex B" (EC type certificate)	Housing DIN Dimensions (WxHxD) Material	71 x 90 x 64.5 mm Nylon PA66, self-extinguishing: UL 94 V-0 DIN-rail
Connections Cable cross-section area AV0-AV2-AV9 models	Screw-type Max. 16 mm ² ; Min. 2.5 mm ² (measuring inputs); Min./Max. screws tightening torque: 1.7 Nm / 3 Nm Other inputs: 1.5 mm ²	Mounting	
		Protection degree Front Screw terminals	IP50 IP20
		Weight	Approx. 400 g (packing included)

Power supply specifications

Self supplied version	AV9-AV0 models "XX" and "O2" options only: -20% +15%, 48-62Hz. "R2", "XS" and "IS" options only: -15% +10%, 48-62Hz. AV2 model: "XX", "O2", "IS" and "DP" options: -15% +15%, 48-62Hz. In case of 3-phase system, 4-wire connection: 113 to 265V. In case of 3-phase system, 3-wire connection: 196 to 460V.	be performed the L1 and L2 voltage inputs have to be short circuited. The instrument provided with "O2" option, working in a 3-phase system with neutral may work also if one or two phases are missing.
Note	The instruments provided with "IS" and "R2" options work only if all the voltage inputs are connected (3-phase and neutral) if a 1-phase connection has to	
	Auxiliary power supply	AV5-AV6 modules: L: 18 to 60VAC/DC; D: 115VAC/230VAC (48 to 62Hz)
	Power consumption AV9-AV2-AV0 models AV9-AV2-AV0 models (IS and DP option only) AV5-AV6 models	≤ 20VA/1W ≤ 12VA/2W ≤ 2VA/2W

Working mode notes (only "Self power supply" version)

Output	Model	Note
Open collector output	"AV0" and "AV9" models with "O2" option	The meter works even if up to two voltages "phase to neutral" are missing or if one voltage "phase to phase" is missing.
Relay output	"AV0" and "AV9" models with "R2" option	The neutral wire has always to be available. The meter works even if "Phase 3" is missing but, mandatorily, both "phase 1" and "Phase 2" have to be available.
RS485 port	"AV0" and "AV9" models with "XS" and "IS" options	
Dupline port	"AV2" model with "DP" option	
Relay output	"AV2" model with "R2" option	The meter works even if up to two voltages "phase to neutral" are missing or if one voltage "phase to phase" is missing.
RS485 port	"AV2" model with "XS", "IS" options	

Accuracy (According to EN62053-21 and EN62053-23)

kWh, accuracy (RDG) depending on the current

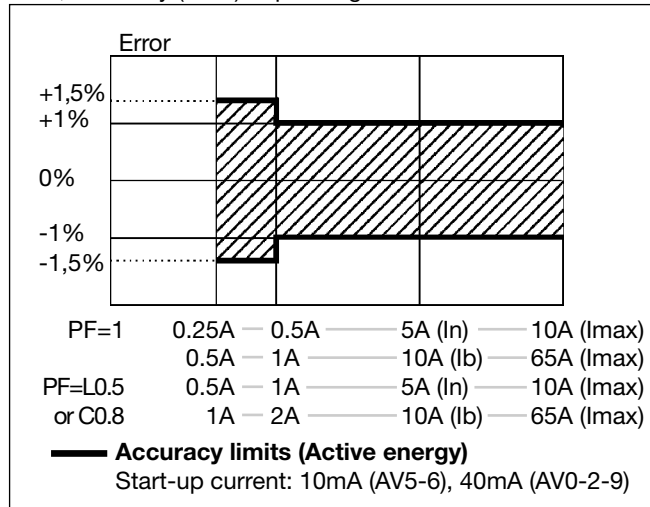

kvarh, accuracy (RDG) depending on the current

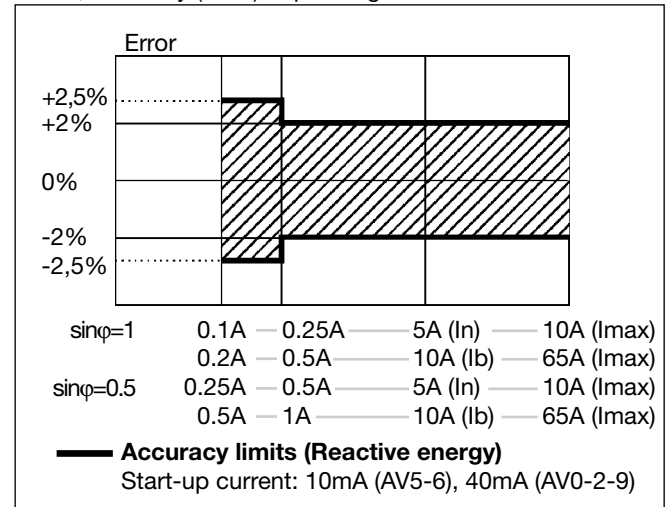

MID “Annex MI-003” compliance

Accuracy

AV0-AV2-AV9 models

$0.9 U_n \leq U \leq 1.1 U_n$;
 $0.98 f_n \leq f \leq 1.02 f_n$;
 fn: 50 or 60Hz;
 cosφ: 0.5 inductive to 0.8 capacitive.
 Class B
 I st: 0.04A;
 I min: 0.5A;
 I tr: 1A;
 I max: 65A.

AV5-AV6 models

Class B
 I st: 0.01A;
 I min: 0.05A;
 I tr: 0.25A;
 I n: 5A;
 I max: 10A

Operating temperature

-25°C to +55°C (-13°F to 131°F) (R.H. from 0 to 90% non-condensing @ 40°C)

EMC compliance

E2

Used calculation formulas

Phase variables

Instantaneous effective voltage

$$V_{1N} = \sqrt{\frac{1}{n} \cdot \sum_1^n (V_{1N})_i^2}$$

Instantaneous active power

$$W_1 = \frac{1}{n} \cdot \sum_1^n (V_{1N})_i \cdot (A_1)_i$$

Instantaneous power factor

$$\cos\varphi_1 = \frac{W_1}{VA_1}$$

Instantaneous effective current

$$A_1 = \sqrt{\frac{1}{n} \cdot \sum_1^n (A_1)_i^2}$$

Instantaneous apparent power

$$VA_1 = V_{1N} \cdot A_1$$

Instantaneous reactive power

$$\text{var}_1 = \sqrt{(VA_1)^2 - (W_1)^2}$$

System variables

Equivalent three-phase voltage

$$V_\Sigma = \frac{V_1 + V_2 + V_3}{3} \cdot \sqrt{3}$$

Voltage asymmetry

$$ASY_{LL} = \frac{(V_{LL \max} - V_{LL \min})}{V_{LL \Sigma}}$$

$$ASY_{LN} = \frac{(V_{LN \max} - V_{LN \min})}{V_{LN \Sigma}}$$

Three-phase reactive power

$$\text{var}_\Sigma = (\text{var}_1 + \text{var}_2 + \text{var}_3)$$

Three-phase active power

$$W_\Sigma = W_1 + W_2 + W_3$$

Three-phase apparent power

$$VA_\Sigma = \sqrt{W_\Sigma^2 + \text{var}_\Sigma^2}$$

Three-phase power factor

$$\cos\varphi_\Sigma = \frac{W_\Sigma}{VA_\Sigma} \quad (\text{TPF})$$

Energy metering

$$k \text{ var hi} = \int_{t_1}^{t_2} Q_i(t) dt \cong \Delta t \sum_{n_1}^{n_2} Q_{nj}$$

$$kWh_i = \int_{t_1}^{t_2} P_i(t) dt \cong \Delta t \sum_{n_1}^{n_2} P_{nj}$$

Where:

i= considered phase (L1, L2 or L3)
 P= active power; Q= reactive power;
 t₁, t₂=starting and ending time points of consumption recording; n= time unit; Δt= time interval between two successive power consumptions;
 n₁, n₂= starting and ending discrete time points of consumption recording

List of the variables that can be connected to:

- RS485 communication port
- Alarm outputs (“max” variable”, “energies” and “hour counter” excluded)
- Pulse outputs (only “energies”)
- Dupline bus

No	Variable	1-phase system	2-phase system	3-ph. 4-wire balanced sys.	3-ph. 4-wire unbal. sys.	3 ph. 3-wire bal. sys.	3 ph. 3-wire unbal. sys.	Notes
1	V L-N sys	o	x	x	x	x	#	sys=system
2	V L1	x	x	x	x	x	#	
3	V L2	o	x	x	x	x	#	
4	V L3	o	o	x	x	x	#	
5	V L-L sys	o	x	x	x	x	x	sys=system
6	V L1-2	#	x	x	x	x	x	
7	V L2-3	#	o	x	x	x	x	
8	V L3-1	#	o	x	x	x	x	
9	A dmd max	o	x	x	x	x	x	Highest “dmd” current among the phases (1)(2)
10	A L1	x	x	x	x	x	x	
11	A L2	o	x	x	x	x	x	
12	A L3	o	o	x	x	x	x	
13	VA sys	x	x	x	x	x	x	sys=system
14	VA sys dmd	x	x	x	x	x	x	sys=system (1)
15	VA L1	x	x	x	x	x	#	
16	VA L2	o	x	x	x	x	#	
17	VA L3	o	o	x	x	x	#	
18	var sys	x	x	x	x	x	#	sys=system
19	var L1	x	x	x	x	x	#	
20	var L2	o	x	x	x	x	#	
21	var L3	o	o	x	x	x	#	
22	W sys	x	x	x	x	x	x	sys=system
23	W sys dmd	x	x	x	x	x	x	sys=system (1)
24	W L1	x	x	x	x	x	#	
25	W L2	o	x	x	x	x	#	
26	W L3	o	o	x	x	x	#	
27	PF sys	x	x	x	x	x	x	
28	PF L1	x	x	x	x	x	#	
29	PF L2	o	x	x	x	x	#	
30	PF L3	o	o	x	x	x	#	
31	Hz	x	x	x	x	x	x	
32	Phase seq.	o	x	x	x	x	x	
33	Hours	x	x	x	x	x	x	
34	kWh (+)	x	x	x	x	x	x	Total or by user
35	kvarh (+)	x	x	x	x	x	#	Total or by user
36	kWh (+)	x	x	x	x	x	x	Partial or by tariff
37	kvarh (+)	x	x	x	x	x	#	Partial or by tariff
38	kWh (-)	x	x	x	x	x	x	Total
39	kvarh (-)	x	x	x	x	x	#	Total
40	m ³ Gas	x	x	x	x	x	x	Total
41	m ³ Cold H ₂ O	x	x	x	x	x	x	Total
42	m ³ Hot H ₂ O	x	x	x	x	x	x	Total
43	kWh H ₂ O	x	x	x	x	x	x	Total

(x) = available

(o) = not available (zero indication on the display)

(#) = not available (the relevant page is not displayed)

(1) = max. value with data storage

(2) = not available with the “DP” option

Display pages

Sel. pos.	No	1st variable (1st line)	2nd variable (2nd line)	3rd variable (3rd line)	Note	Applications							
						A	B	C	D	E	F	G	H
	1	Phase seq.	VLN sys	Hz		7	7	7		7	7	7	7
	2	Phase seq.	VLL sys	Hz							x	x	x
	3	Total kWh (+)	W sys dmd	W sys dmd max		x	x	x		x	x	x	x
	4	kWh (+)	A dmd max	(text) "PArT"	"PArT" = Partial kWh (+)						x	x	x
	5	Total kvarh (+)	VA sys dmd	VA sys dmd max			7	7			7	7	7
	6	kvarh (+)	VA sys	(text) "PArT"	"PArT" = Partial kvarh (+)						7	7	7
	7	Totalizer 1 (2)	W sys	(text) (3)	(1)			x			x	x	x
	8	Totalizer 2 (2)	W sys	(text) (3)	(1)			x			x	x	x
	9	Totalizer 3 (2)	W sys	(text) (3)	(1)			x			x	x	x
	10	kWh (+)	t1 tariff (4)	W sys dmd	(1) digital input enabled			x			x	x	x
	11	kWh (+)	t2 tariff (4)	W sys dmd	(1) digital input enabled			x			x	x	x
	12	kWh (+)	t3 tariff (4)	W sys dmd	(1) digital input enabled			5			5	5	5
	13	kWh (+)	t4 tariff (4)	W sys dmd	(1) digital input enabled			5			5	5	5
	14	kvarh (+)	t1 tariff (4)	W sys dmd	(1) digital input enabled			7			7	7	7
	15	kvarh (+)	t2 tariff (4)	W sys dmd	(1) digital input enabled			7			7	7	7
	16	kvarh (+)	t3 tariff (4)	W sys dmd	(1) digital input enabled			5,7			5,7	5,7	5,7
	17	kvarh (+)	t4 tariff (4)	W sys dmd	(1) digital input enabled			5,7			5,7	5,7	5,7
	18	kWh (+) X	W X	User X	(1) specific function enabled				x				
	19	kWh (+) Y	W Y	User Y	(1) specific function enabled				x				
	20	kWh (+) Z	W Z	User Z	(1) specific function enabled				x				
	21	Total kvarh (-)	VA sys dmd	VA sys dmd max							7		7
	22	Total kWh (-)	W sys dmd	W sys dmd max						x	x		x
	23	Hours	W sys	PF sys						x	x	x	x
	24	Hours	var sys	PF sys						7	7	7	7
	25	var L1	var L2	var L3								7	7
	26	VA L1	VA L2	VA L3								7	7
	27	PF L1	PF L2	PF L3								7	7
	28	W L1	W L2	W L3						7		7	7
	29	A L1	A L2	A L3						x		x	x
	30	V L1-2	V L2-3	V L3-1								6	6
	31	V L1	V L2	V L3			7		7	7		7	7
0	Selector position which can be linked to any of the variable combinations listed above (No. from 1 to 31)												
1	Selector position which can be linked to any of the variable combinations listed above (No. from 1 to 31)												
2	Selector position which can be linked to any of the variable combinations listed above (No. from 1 to 31)												
3	Selector position which can be linked to any of the variable combinations listed above (No. from 1 to 31) In this position the front LED blinks proportionally to the reactive energy (kvarh) being measured												

- (1) The page is available according to the enabled measurement.
(2) m³ Gas, m³ Water, kWh remote heating.
(3) Hot and Cold (water), GAS.
(4) The active tariff is displayed with an "A" before the "t1-t2-t3-t4" symbols.
(5) These pages are not available in case of Dupline system.
(6) Pages not available in case of 1-phase system (1P selection).
(7) Pages not available in case of 3-phase unbalanced system (3P selection).

Note: in case of alarm the whole display blinks. The blinking stops when either the selector or the joystick are used. The display starts to blink again after 60 seconds of the last command being used. There is a time-out of 60s that brings the scrolled page to the default one (selectable according to the table given above).

Additional available information on the display

Type	1st line	2nd line	3rd line
Meter information	Firmware revision	YEAr (text)	Year of production
Meter information	PuLSE (text)	LEd (text)	Numb. of kWh per pulse
Meter information	System (1-2-3-phase)	Connection (2-3-4-wire)	dmd (time)
Meter information	VT/PT ratio		
Meter information (AV5-6)	Ct rAtio (text)	1.0 ... 60.0k	
Meter information (AV5-6)	UT rAtio (text)	1.0 ...6.0k	
In case of communication port	SErIAL (text)	Address number	RS485 status (RX-TX)
In case of Dupline port	Dupline (text) or EM24 (text)	OK ... err	

List of selectable applications

	Description	Notes
A	Basic domestic	Mainly energy metering
B	Shopping centres	Mainly energy metering
C	Advanced domestic	Mainly energy metering (total and based on tariff), gas and water metering
D	Multi domestic (also camping and marinas)	Mainly energy metering (3 by single phase)
E	Solar	Energy meter with some basic power analyzer functions
F	Industrial	Mainly energy metering
G	Advanced industrial	Energy metering and power analysis
H	Advanced industrial for power generation	Complete energy metering and power analysis

Insulation between inputs and outputs

	Measuring Inputs	Relay outputs	Open collector outputs	Comm. port and digital inputs	Dupline	Self power supply	Auxiliary power supply
Measuring Inputs	-	4kV	4kV	4kV	4kV	0kV	4kV
Relay outputs	4kV	-	-	-	-	4kV	4kV
Open collector outputs	4kV	-	-	-	-	4kV	4kV
Comm. port and digital inputs	4kV	-	-	-	-	4kV	4kV
Dupline	4kV	-	-	-	-	4kV	4kV
Self power supply	0kV	4kV	4kV	4kV	4kV	-	-
Aux. power supply	4kV	4kV	4kV	4kV	4kV	-	-

NOTE: all the models with auxiliary power supply have, mandatorily, to be connected to external current transformers because the isolation among the current inputs is just functional (100VAC).

Tamper proof accessory kit



The "tamper proof" kit is available with the "P" option (two screw protection covers).

The instrument can be sealed in three points:

- Upper cover;
- Lower cover;
- Front selector (to lock the instrument programming);



Wiring diagrams

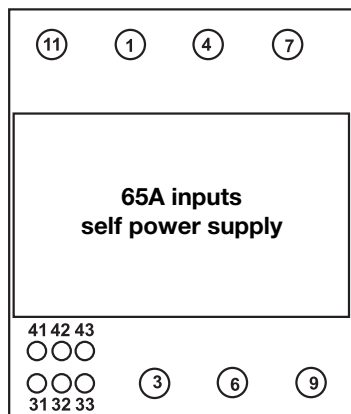

(65A) System type selection: 3P.n

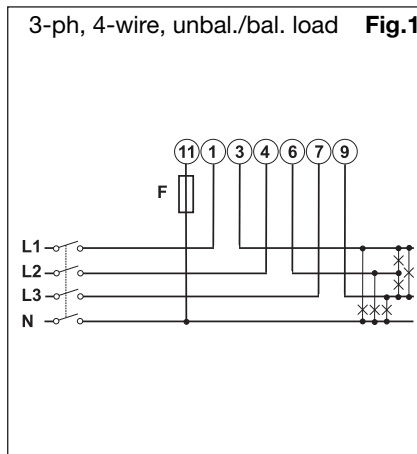

(65A) System type selection: 3P

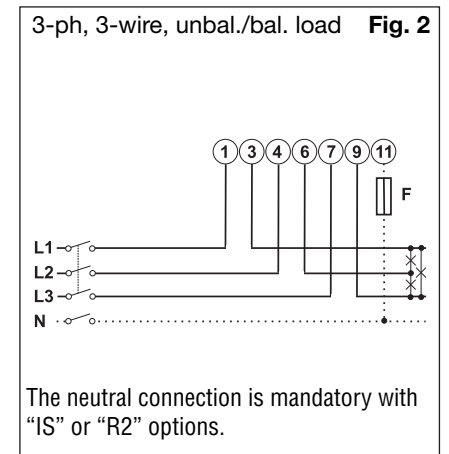

(65A) System type selection: 2P

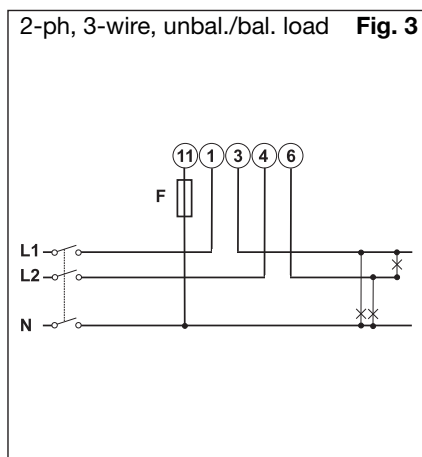

(65A) System type selection: 1P

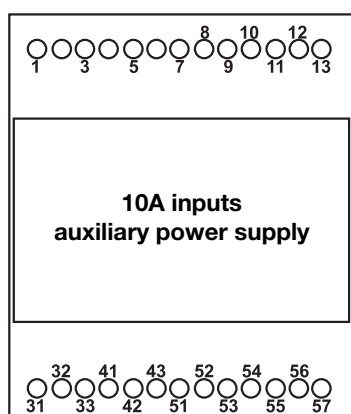
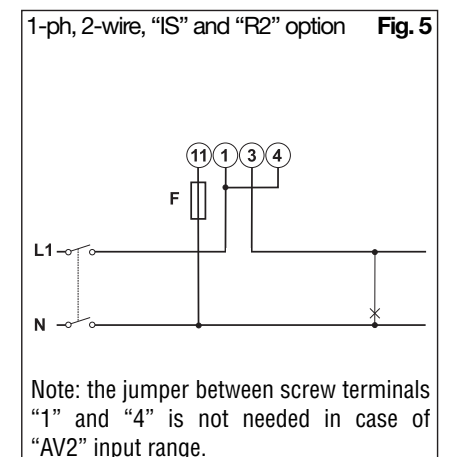
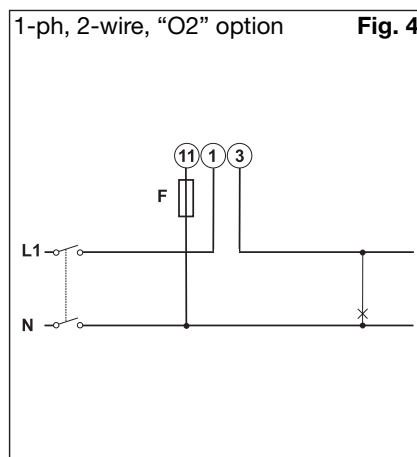

(10A) System type selection: 3P.n

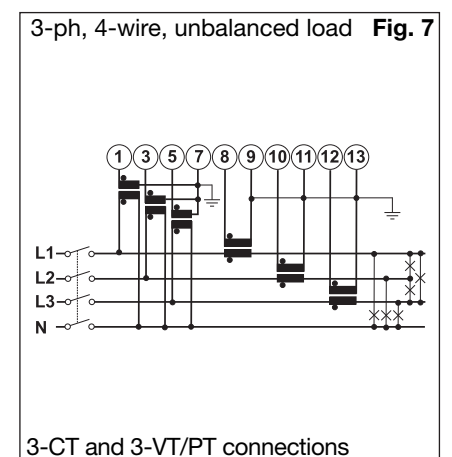
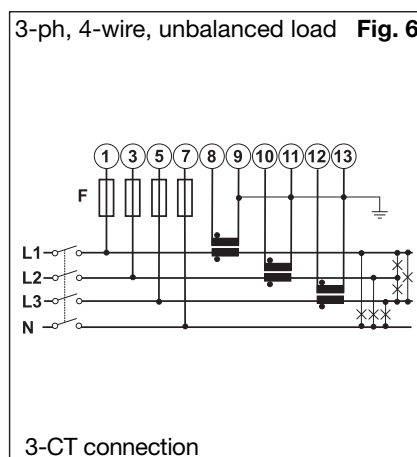

Wiring diagrams

(10A) System type selection: 3P.n

3-ph, 3-wire, unbalanced load **Fig. 8**

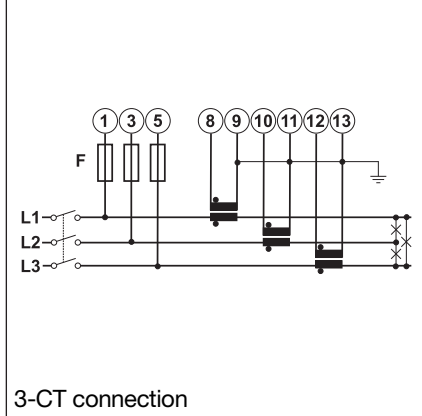

3-ph, 3-wire, unbalanced load **Fig. 9**

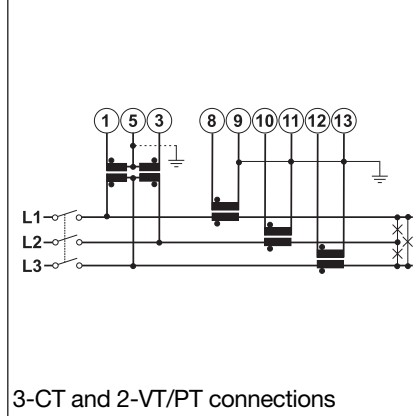

3-ph, 3-wire, unbalanced load **Fig. 10**

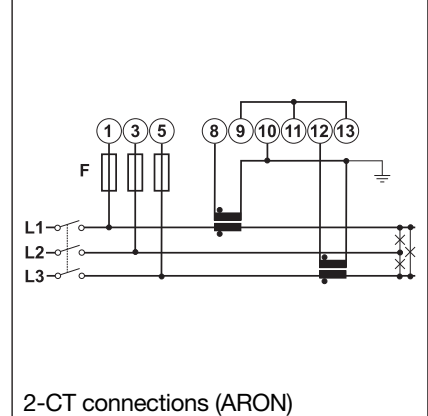

(10A) System type selection: 3P.1

3-ph, 3-wire, unbalanced load **Fig. 11**

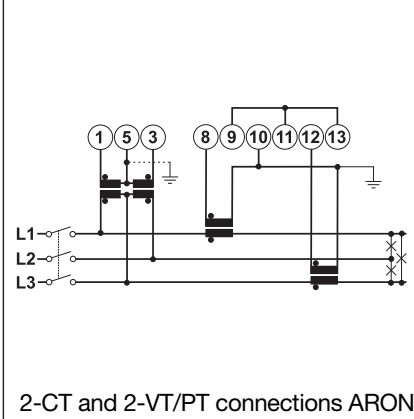

3-ph, 3-wire, balanced load **Fig. 12**

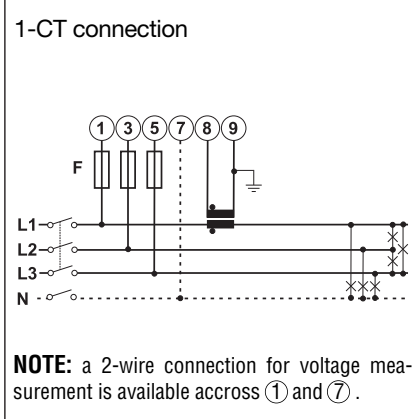

3-ph, 3-wire, balanced load **Fig. 13**

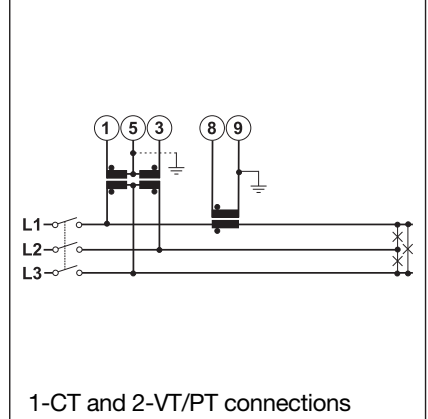

(10A) System type selection: 2P

2-ph, 3-wire **Fig. 14**

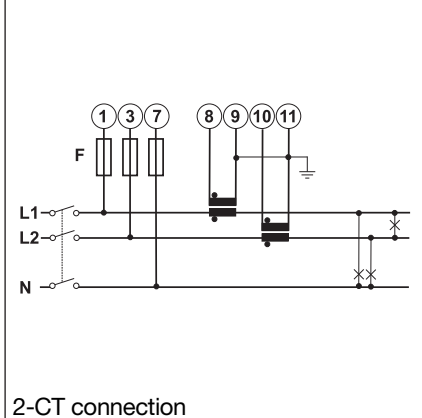

2-ph, 3-wire **Fig. 15**

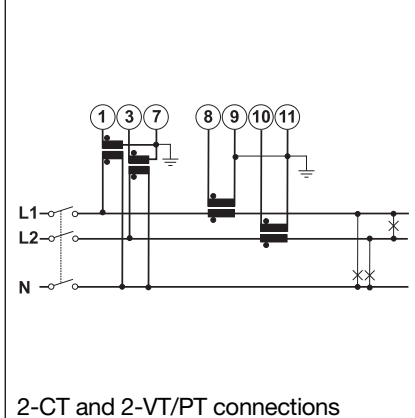

(10A) System type selection: 1P

1-ph, 2-wire **Fig. 16**

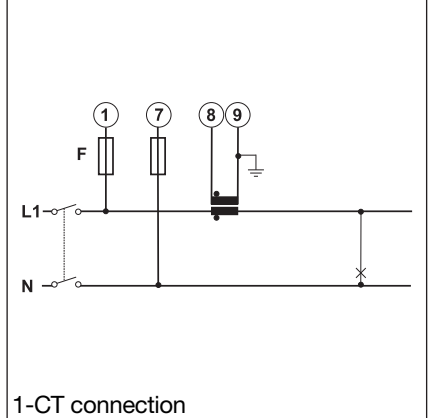

Wiring diagrams

(10A) System type selection: 1P

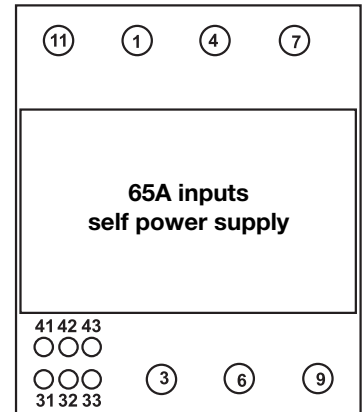
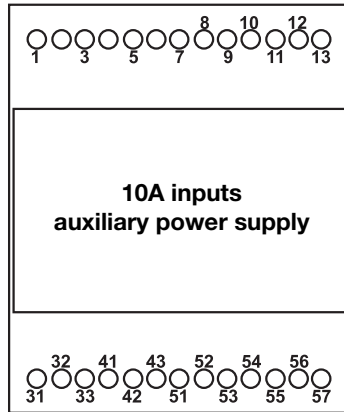
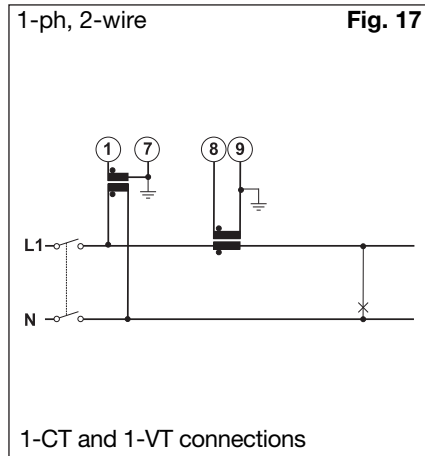

Power supply wiring diagrams (auxiliary power supply)

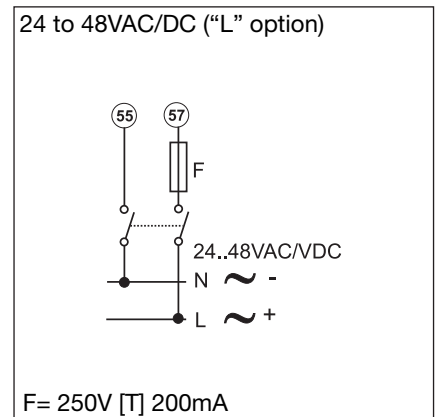
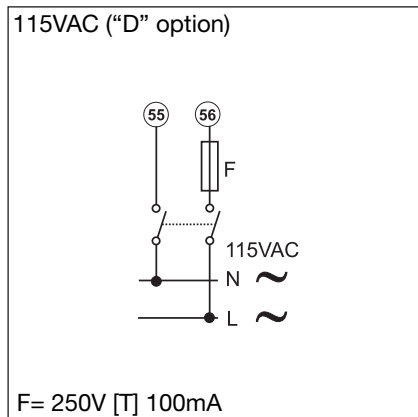
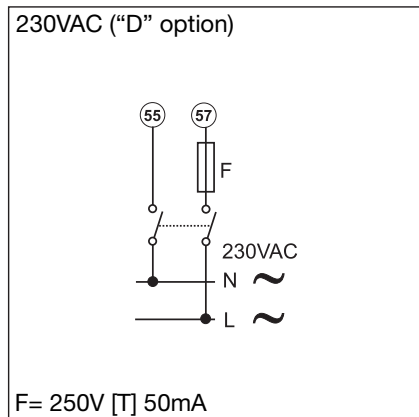

Open collector and relay outputs wiring diagrams

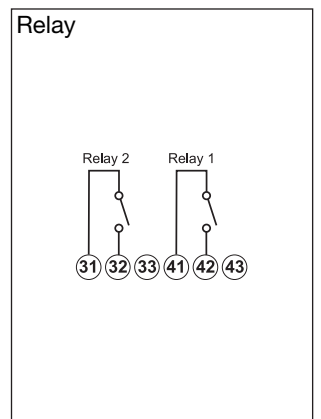
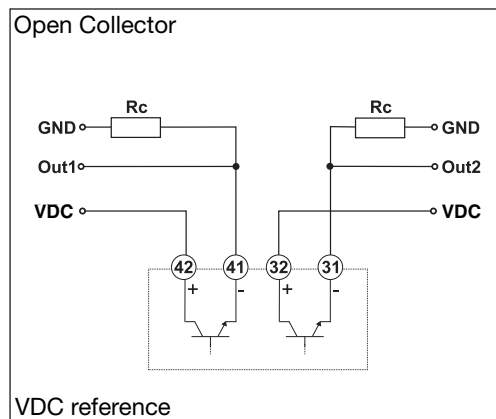
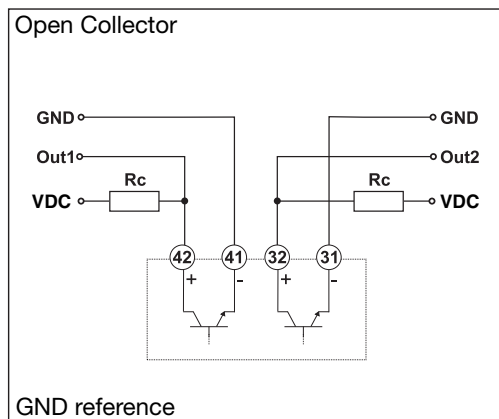

The load resistances (RC) must be designed so that the close contact current is lower than 100mA; the VDC voltage must be lower than or equal to 30VDC.

Digitala inputs, RS485 and Dupline ports wiring diagrams

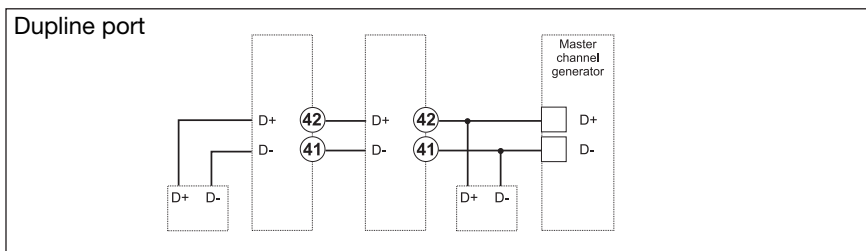
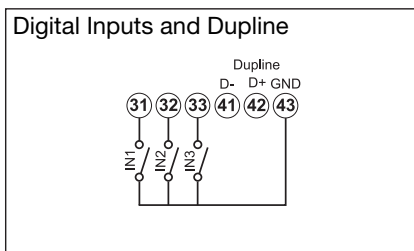
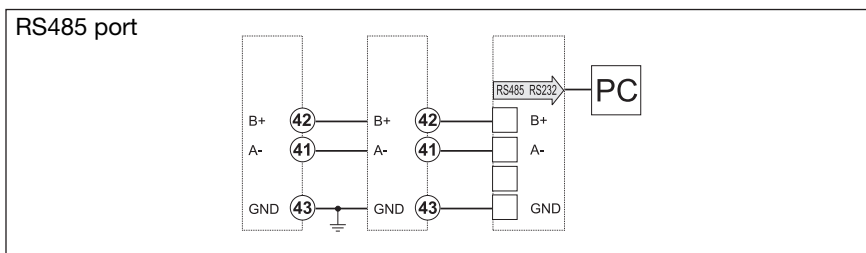
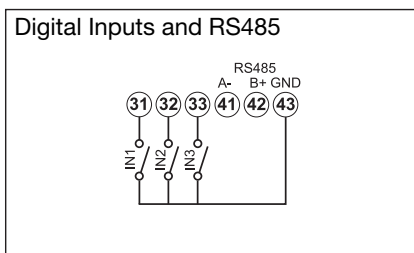

Front panel description

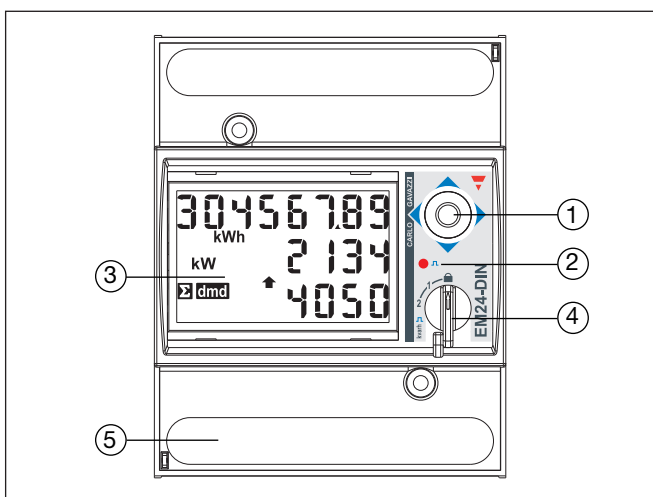

1. **Joystick**
To program the configuration parameters and scroll the variables on the display.
2. **LED**
Red LED blinking proportional to the energy being measured.
3. **Display**
LCD-type with alphanumeric indications to:
- display configuration parameters;
- display all the measured variables.
4. **Selector**
To select the desired display pages and to lock the programming.
5. **Connections**
Screw terminal blocks for instrument wiring.

Dimensions

